

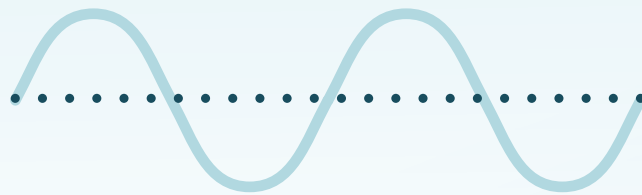

NTS & NTU Series

User Manual



True Sine Wave Inverter

• High Reliable Inverter •

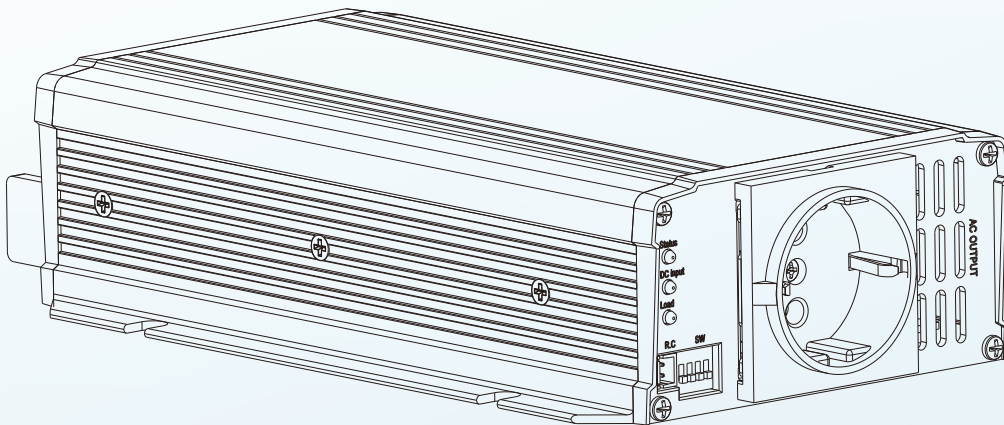

NTS/NTU series are MEAN WELL's new generation high-reliability off-grid DC-AC pure sine wave inverters. The whole family has NTS-250P/400P, NTS-300/450/750/1200/1700/2200/3200, and NTU-1200/1700/2200/3200 series. The whole family of NTS/NTU are fully digital designed, with three major characteristics of miniaturization, high efficiency, and intelligence. The main features are, instantaneous peak load capacity which can reach up to 2 times of output wattage, as well as AC output voltage/frequency/power saving mode adjustment capability through the DIP switch of front panel (the idle standby consumption is 1.5W). It's efficiency reaches up to 93%, and it can be operated within temperature range from -25~+70°C. Built-in remote control, able to monitor the battery voltage and the load status of the inverter through IRC1/2/3. Not only intergrated multiple intelligent protections, but also passed safety regulations such as CB/DEKRA/E13/EAC/UL/RCM/FCC/CE/UKCA. Materials and components are strictly selected and 3-year warranty is provided. It is suitable for households, vehicles, yacht and remote areas without power grids. Common application such as, lighting, air conditioning, refrigerators, hair dryers, microwave ovens, computers, televisions, hand-held power tools, motor equipment, mobile AC power... etc.

Index

1.Safety Guidelines	1	6.Protections and Failure Correction	61
2.Introduction	2	6.1 Protections	61
2.1 Model number	2	6.2 Failure Correction	62
2.2 Features	2	7.Warranty	63
2.3 Main specification	3	8.Environmental declaration information	64
2.4 Safety Overview	16		
2.5 Derating curve	17		
2.6 Mechanical specification	18		
3.Installation & Wiring	24		
3.1 Precautions	24		
3.2 System Block Diagram	24		
3.3 Installation procedures	25		
3.4 Cable selection	25		
3.5 Battery selection	26		
3.6 GFCI socket	26		
4.User Interface Panel	27		
4.1 AC panel	27		
4.2 DC panel	29		
4.3 LED indicator	30		
5.Explanation of settings	32		
5.1 Procedure of Setting	32		
Operating Mode, Output Voltage, Frequency, and power Saving Mode			
5.2 Function difference	34		
5.3 IRC1/IRC2/IRC3 Remote control unit	34		
5.4 RS-232/UART protocol	35		
5.5 UPS mode(only for NTU series)	59		

1.Safety Guidelines

- Risk of electrical shock and energy hazard. All failures should be examined by the qualified technician. Please do not remove the case of the inverter by yourself.
 - Please do not install the inverter in places with high moisture or near water.
 - Please do not install the inverter in places with high ambient temperature or under direct sunlight.
 - Please only connect batteries with the same brand and model number in one battery bank. Using batteries from different manufacturers or different capacity is strictly prohibited!
 - Never allow a spark or flame in the vicinity of the batteries because they may ignite explosive gases during normal operation.
 - Make sure the air flow from the fan is not obstructed at both sides (front and back) of the inverter. (Please allow at least 15cm of space)
 - Please do not stack any object on the inverter.
 - Please do not turn on the inverter before start the engine if inverter connected to vehicle's battery directly.
 - Branch rated over current protection for the AC output circuit is to be provided at the time of installation.
-
- Risque de choc électrique et danger d'électrocution. Toutes les pannes doivent être examinées par un technicien qualifié. Veuillez ne pas retirer vous-même le boîtier de l'onduleur.
 - N'installez pas l'onduleur dans des endroits très humides ou à proximité d'eau.
 - N'installez l'onduleur dans des endroits où la température ambiante est élevée ou sous la lumière directe du soleil.
 - Veuillez ne insérer que des batteries de la même marque et du même modèle dans un seul banc de batteries. L'utilisation de batteries de fabricants différents ou de capacités différentes est strictement interdite!
 - Ne laissez jamais une étincelle ou une flamme à proximité des batteries car elles peuvent enflammer des gaz explosifs lors du fonctionnement normal.
 - Assurez-vous que le flux d'air du ventilateur n'est pas obstrué des deux côtés (avant et arrière) de l'onduleur. (Veuillez laisser au moins 15 cm d'espace)
 - N'empilez aucun objet sur l'onduleur.
 - N'allumez pas l'onduleur avant de démarrer le moteur si l'onduleur est connecté directement à la batterie du véhicule.
 - Une protection contre les surintensités nominales de dérivation pour le circuit de sortie AC doit être fournie au moment de l'installation.

2.Introduction

2.1 Model number

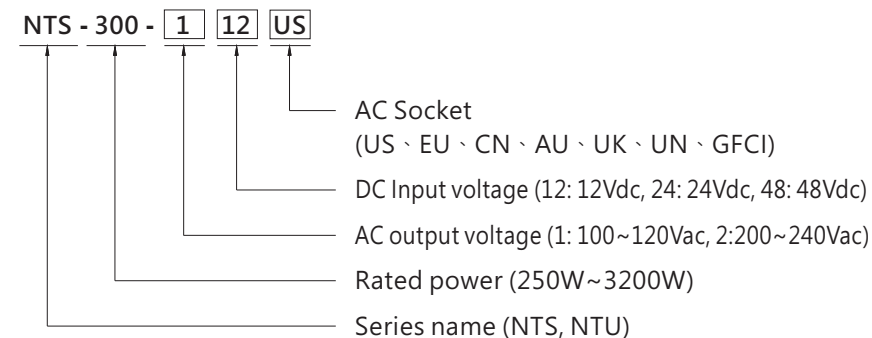

2.2 Features

- Full digital design with compact size and light weight.
- True sine wave output(THD<3%)
- Peak power up to 1.7~ 2 times
- AC voltage, frequency, power saving mode selectable.
- Multiple intelligent protections
DC Input : Reverse polarity protection/ Low DC voltage protection/ DC over voltage protection.
AC Output : Short circuit protection, over load protection, over temperature protection.
- LED indicator : Status, DC input, load status, AC input.
- Built-in Remote control
- Support IRC1/2/3 for 750~3200W models(optional)
- UPS functions(only for NTU series)
- Wide range of DC input voltage for lead acid or lithium batteries.
- CB/DEKRA/E13/EAC/UL/RCM/FCC/CE/UKCA certified.
- 3 year warranty

2.3 Specification

NTS-250P series

MODEL		NTS-250P-112	NTS-250P-124	NTS-250P-148	NTS-250P-212	NTS-250P-224	NTS-250P-248			
OUTPUT	RATED POWER(Continuous)	250W								
	OVER RATED POWER(3 Min.)	287.5W								
	PEAK POWER(10 Sec.)	375W								
	SURGE POWER(30 Cycles)	500W								
	AC VOLTAGE	Default setting set at 110VAC			Default setting set at 230VAC					
		100 / 110 / 115 / 120Vac selectable by DIP S.W			200 / 220 / 230 / 240Vac selectable by DIP S.W					
	FREQUENCY	Default setting set at 60Hz±0.1Hz			Default setting set at 50Hz±0.1Hz					
		50/60Hz selectable by DIP S.W			50/60Hz selectable by DIP S.W					
	WAVEFORM	Note.1 True sine wave (THD<3%)								
AC REGULATION	±3.0% at rated input voltage									
LED STATUS	Please refer to section 3.4 of installation manual									
INPUT	BAT. VOLTAGE	12V	24V	48V	12V	24V	48V			
	VOLTAGE RANGE (Typ.)	10 ~ 16.5Vdc	20 ~ 33Vdc	40 ~ 66Vdc	10 ~ 16.5Vdc	20 ~ 33Vdc	40 ~ 66Vdc			
	DC CURRENT (Typ.)	25A	13A	7A	25A	13A	7A			
	NO LOAD DISSIPATION (Typ.)	NON-SAVING MODE	10W	10W	12W	10W	10W	12W		
		SAVING MODE	Default disable, ≤1.2W ~ 1.5W by models @ auto detec AC output load ≤10W will be changed to saving mode							
	OFF MODE CURRENT DRAW	<1mA at battery ~DC input must be disconnected								
	EFFICIENCY (Typ.)	Note.1 91%	91%	92%	92%	93%	93%			
	BATTERY TYPES	Lead Acid or li-ion								
PROTECTION	DC INPUT	FUSE (INTERNAL)	30A*2	30A*1	10A*2	30A*2	30A*1	10A*2		
			LOW	ALARM	11±0.3Vdc	22±0.5Vdc	44±1Vdc	11±0.3Vdc	22±0.5Vdc	44±1Vdc
				SHUTDOWN	10±0.3Vdc	20±0.5Vdc	40±1Vdc	10±0.3Vdc	20±0.5Vdc	40±1Vdc
		RESTART		12.5±0.3Vdc	25±0.5Vdc	50±1Vdc	12.5±0.3Vdc	25±0.5Vdc	50±1Vdc	
		HIGH	ALARM	15.5±0.3Vdc	31±0.5Vdc	62±1Vdc	15.5±0.3Vdc	31±0.5Vdc	62±1Vdc	
			SHUTDOWN	16.5±0.3Vdc	33±0.5Vdc	66±1Vdc	16.5±0.3Vdc	33±0.5Vdc	66±1Vdc	
	RESTART		15±0.3Vdc	30±0.5Vdc	60±1Vdc	15±0.3Vdc	30±0.5Vdc	60±1Vdc		
	BAT. POLARITY	By internal fuse open								
	AC OUTPUT	OVER TEMPERATURE	Protection type : Shut down o/p voltage, re-power on to recover							
		OUTPUT SHORT	Protection type : Shut down o/p voltage, re-power on to recover							
OVER LOAD (Typ.)		105 ~ 115% load for 180 sec., 115% ~ 150% load for 10 sec. Protection type : Shut down o/p voltage, re-power on to recover								
FUNCTION	REMOTE CONTROL DRY CONTACT	Power ON-OFF remote control by front panel dry contact connector (by RELAY) Open : Normal work ; Short : Remote off								
ENVIRON- MENT	WORK TEMP.	-20 ~ +70°C (Refer to "Derating curve")								
	WORKING HUMIDITY	20 ~ 90% RH non-condensing								
	STORAGE TEMP., HUMIDITY	-30 ~ +70°C / -22 ~ +158°F, 10 ~ 95% RH non-condensing								
	VIBRATION	10 ~ 500Hz, 3G 10min./1cycle, 60min. each along X, Y, Z axes								
OTHER	MTBF	279K hrs min. Telcordia TR/SR-332 (Bellcore) ; 84K hrs min. MIL-HDBK-217F (25°C)								
	DIMENSION	186*100.5*32mm (L*W*H)								
	PACKING	0.75Kg; 18pcs/ 14.5Kg/ 0.97CUFT								

NTS-400P series

MODEL		NTS-400P-112	NTS-400P-124	NTS-400P-148	NTS-400P-212	NTS-400P-224	NTS-400P-248			
OUTPUT	RATED POWER(Continuous)	400W								
	OVER RATED POWER(3 Min.)	460W								
	PEAK POWER(10 Sec.)	600W								
	SURGE POWER(30 Cycles)	800W								
	AC VOLTAGE	Default setting set at 110VAC			Default setting set at 230VAC					
		100 / 110 / 115 / 120Vac selectable by DIP S.W			200 / 220 / 230 / 240Vac selectable by DIP S.W					
	FREQUENCY	Default setting set at 60Hz±0.1Hz			Default setting set at 50Hz±0.1Hz					
		50/60Hz selectable by DIP S.W			50/60Hz selectable by DIP S.W					
	WAVEFORM	Note.1 True sine wave (THD<3%)								
AC REGULATION	±3.0% at rated input voltage									
LED STATUS	Please refer to section 3.4 of installation manual									
INPUT	BAT. VOLTAGE	12V	24V	48V	12V	24V	48V			
	VOLTAGE RANGE (Typ.)	10 ~ 16.5Vdc	20 ~ 33Vdc	40 ~ 66Vdc	10 ~ 16.5Vdc	20 ~ 33Vdc	40 ~ 66Vdc			
	DC CURRENT (Typ.)	40A	20A	10A	40A	20A	10A			
	NO LOAD DISSIPATION (Typ.)	NON-SAVING MODE	10W	10W	12W	10W	10W	12W		
		SAVING MODE	Default disable, ≤1.2W ~ 1.5W by models @ auto detec AC output load ≤10W will be changed to saving mode							
	OFF MODE CURRENT DRAW	<1mA at battery ~DC input must be disconnected								
	EFFICIENCY (Typ.)	Note.1 89%	91%	91%	91%	93%	93%			
	BATTERY TYPES	Lead Acid or li-ion								
PROTECTION	DC INPUT	FUSE (INTERNAL)	40A*2	30A*2	10A*2	40A*2	30A*2	10A*2		
			LOW	ALARM	11±0.3Vdc	22±0.5Vdc	44±1Vdc	11±0.3Vdc	22±0.5Vdc	44±1Vdc
				SHUTDOWN	10±0.3Vdc	20±0.5Vdc	40±1Vdc	10±0.3Vdc	20±0.5Vdc	40±1Vdc
		RESTART		12.5±0.3Vdc	25±0.5Vdc	50±1Vdc	12.5±0.3Vdc	25±0.5Vdc	50±1Vdc	
		HIGH	ALARM	15.5±0.3Vdc	31±0.5Vdc	62±1Vdc	15.5±0.3Vdc	31±0.5Vdc	62±1Vdc	
			SHUTDOWN	16.5±0.3Vdc	33±0.5Vdc	66±1Vdc	16.5±0.3Vdc	33±0.5Vdc	66±1Vdc	
	RESTART		15±0.3Vdc	30±0.5Vdc	60±1Vdc	15±0.3Vdc	30±0.5Vdc	60±1Vdc		
	BAT. POLARITY	By internal fuse open								
	AC OUTPUT	OVER TEMPERATURE	Protection type : Shut down o/p voltage, re-power on to recover							
		OUTPUT SHORT	Protection type : Shut down o/p voltage, re-power on to recover							
OVER LOAD (Typ.)		105 ~ 115% load for 180 sec., 115% ~ 150% load for 10 sec. Protection type : Shut down o/p voltage, re-power on to recover								
FUNCTION	REMOTE CONTROL DRY CONTACT	Power ON-OFF remote control by front panel dry contact connector (by RELAY) Open : Normal work ; Short : Remote off								
ENVIRON- MENT	WORK TEMP.	-20 ~ +70°C (Refer to "Derating curve")								
	WORKING HUMIDITY	20 ~ 90% RH non-condensing								
	STORAGE TEMP., HUMIDITY	-30 ~ +70°C / -22 ~ +158°F, 10 ~ 95% RH non-condensing								
	VIBRATION	10 ~ 500Hz, 3G 10min./1cycle, 60min. each along X, Y, Z axes								
OTHER	MTBF	278.7K hrs min. Telcordia TR/SR-332 (Bellcore) ; 84K hrs min. MIL-HDBK-217F (25°C)								
	DIMENSION	186*100.5*32mm (L*W*H)								
	PACKING	0.75Kg; 18pcs/ 14.5Kg/ 0.97CUFT								

NTS-300 series

MODEL		NTS-300-112 <input type="checkbox"/> NTS-300-124 <input type="checkbox"/> NTS-300-148 <input type="checkbox"/>		NTS-300-212 <input type="checkbox"/> NTS-300-224 <input type="checkbox"/> NTS-300-248 <input type="checkbox"/>					
		<input type="checkbox"/> = US, GFCI, UN		<input type="checkbox"/> = EU, CN, AU, UK, UN					
OUTPUT	RATED POWER(Continuous)	300W							
	OVER RATED POWER(3 Min.)	345W							
	PEAK POWER(10 Sec.)	450W							
	SURGE POWER(30 Cycles)	600W							
	AC VOLTAGE	Default setting set at 110VAC 100 / 110 / 115 / 120Vac selectable by DIP S.W		Default setting set at 230VAC 200 / 220 / 230 / 240Vac selectable by DIP S.W					
	FREQUENCY	Default setting set at 60Hz±0.1Hz 50/60Hz selectable by DIP S.W		Default setting set at 50Hz±0.1Hz 50/60Hz selectable by DIP S.W					
	WAVEFORM	Note.1 True sine wave (THD<3%)							
	AC REGULATION	±3.0% at rated input voltage							
FRONT PANEL LED		Please refer to section 3.4 of installation manual							
INPUT	BAT. VOLTAGE	12V	24V	48V	12V	24V	48V		
	VOLTAGE RANGE (Typ.)	10 ~ 16.5Vdc	20 ~ 33Vdc	40 ~ 66Vdc	10 ~ 16.5Vdc	20 ~ 33Vdc	40 ~ 66Vdc		
	DC CURRENT (Typ.)	30A	15A	8A	30A	15A	8A		
	NO LOAD	10W	10W	12W	10W	10W	12W		
	DISSIPATION (Typ.)	NON-SAVING MODE	Default disable, ≤1.2W ~ 1.5W by models @ auto detec AC output load ≤10W will be changed to saving mode						
		SAVING MODE	1.2W	1.3W	1.5W	1.2W	1.3W	1.5W	
	OFF MODE CURRENT DRAW	≤1mA							
	EFFICIENCY (Typ.)	Note.1 90%		92%	92%	92%	93%	93%	
BATTERY TYPES		Lead Acid or li-ion							
PROTECTION	DC INPUT	FUSE (INTERNAL)		30A*2	30A*1	10A*2	30A*2	30A*1	10A*2
		LOW	ALARM	11±0.3Vdc	22±0.5Vdc	44±1Vdc	11±0.3Vdc	22±0.5Vdc	44±1Vdc
			SHUTDOWN	10±0.3Vdc	20±0.5Vdc	40±1Vdc	10±0.3Vdc	20±0.5Vdc	40±1Vdc
			RESTART	12.5±0.3Vdc	25±0.5Vdc	50±1Vdc	12.5±0.3Vdc	25±0.5Vdc	50±1Vdc
		HIGH	ALARM	15.5±0.3Vdc	31±0.5Vdc	62±1Vdc	15.5±0.3Vdc	31±0.5Vdc	62±1Vdc
			SHUTDOWN	16.5±0.3Vdc	33±0.5Vdc	66±1Vdc	16.5±0.3Vdc	33±0.5Vdc	66±1Vdc
	RESTART		15±0.3Vdc	30±0.5Vdc	60±1Vdc	15±0.3Vdc	30±0.5Vdc	60±1Vdc	
	BAT. POLARITY		By internal fuse open						
	OVER TEMPERATURE		Protection type : Shut down o/p voltage, re-power on to recover						
	OUTPUT SHORT		Protection type : Shut down o/p voltage, re-power on to recover						
	OVER LOAD (Typ.)		105 ~ 115% load for 180 sec., 115% ~ 150% load for 10 sec. Protection type : Shut down o/p voltage, re-power on to recover						
	GFCI PROTECTION		Design refer to UL458 (Only for "GFCI" AC socket, by request)		None				
FUNCTION	REMOTE CONTROL DRY CONTACT	Power ON-OFF remote control by front panel dry contact connector (by RELAY) Open : Normal work ; Short : Remote off							
ENVIRON-MENT	WORK TEMP.	-25 ~ +65°C (Refer to "Derating curve")							
	WORKING HUMIDITY	20 ~ 90% RH non-condensing							
	STORAGE TEMP., HUMIDITY	-30 ~ +70°C / -22 ~ +158°F, 10 ~ 95% RH non-condensing							
	VIBRATION	10 ~ 500Hz, 3G 10min./1cycle, 60min. each along X, Y, Z axes							
OTHER	MTBF	281.9K hrs min. Telcordia TR/SR-332 (Bellcore); 85.3K hrs min. MIL-HDBK-217F (25°C)							
	DIMENSION	210*130*55mm (L*W*H)							
	PACKING	1.3Kg; 8pcs/ 11.4Kg/ 1.74CUFT							

NTS-450 series

MODEL		NTS-450-112 <input type="checkbox"/> NTS-450-124 <input type="checkbox"/> NTS-450-148 <input type="checkbox"/>		NTS-450-212 <input type="checkbox"/> NTS-450-224 <input type="checkbox"/> NTS-450-248 <input type="checkbox"/>					
		<input type="checkbox"/> = US, GFCI, UN		<input type="checkbox"/> = EU, CN, AU, UK, UN					
OUTPUT	RATED POWER(Continuous)	450W							
	OVER RATED POWER(3 Min.)	517.5W							
	PEAK POWER(10 Sec.)	675W							
	SURGE POWER(30 Cycles)	900W							
	AC VOLTAGE	Default setting set at 110VAC 100 / 110 / 115 / 120Vac selectable by DIP S.W		Default setting set at 230VAC 200 / 220 / 230 / 240Vac selectable by DIP S.W					
	FREQUENCY	Default setting set at 60Hz±0.1Hz 50/60Hz selectable by DIP S.W		Default setting set at 50Hz±0.1Hz 50/60Hz selectable by DIP S.W					
	WAVEFORM	Note.1 True sine wave (THD<3%)							
	AC REGULATION	±3.0% at rated input voltage							
FRONT PANEL LED		Please refer to section 3.4 of installation manual							
INPUT	BAT. VOLTAGE	12V	24V	48V	12V	24V	48V		
	VOLTAGE RANGE (Typ.)	10 ~ 16.5Vdc	20 ~ 33Vdc	40 ~ 66Vdc	10 ~ 16.5Vdc	20 ~ 33Vdc	40 ~ 66Vdc		
	DC CURRENT (Typ.)	50A	25A	14A	50A	25A	14A		
	NO LOAD	10W	10W	12W	10W	10W	12W		
	DISSIPATION (Typ.)	NON-SAVING MODE	Default disable, ≤1.2W ~ 1.5W by models @ auto detec AC output load ≤10W will be changed to saving mode						
		SAVING MODE	1.2W	1.3W	1.5W	1.2W	1.3W	1.5W	
	OFF MODE CURRENT DRAW	≤1mA							
	EFFICIENCY (Typ.)	Note.1 88%		91%	91%	90%	93%	93%	
BATTERY TYPES		Lead Acid or li-ion							
PROTECTION	DC INPUT	FUSE (INTERNAL)		40A*2	40A*1	10A*2	40A*2	40A*1	10A*2
		LOW	ALARM	11±0.3Vdc	22±0.5Vdc	44±1Vdc	11±0.3Vdc	22±0.5Vdc	44±1Vdc
			SHUTDOWN	10±0.3Vdc	20±0.5Vdc	40±1Vdc	10±0.3Vdc	20±0.5Vdc	40±1Vdc
			RESTART	12.5±0.3Vdc	25±0.5Vdc	50±1Vdc	12.5±0.3Vdc	25±0.5Vdc	50±1Vdc
		HIGH	ALARM	15.5±0.3Vdc	31±0.5Vdc	62±1Vdc	15.5±0.3Vdc	31±0.5Vdc	62±1Vdc
			SHUTDOWN	16.5±0.3Vdc	33±0.5Vdc	66±1Vdc	16.5±0.3Vdc	33±0.5Vdc	66±1Vdc
	RESTART		15±0.3Vdc	30±0.5Vdc	60±1Vdc	15±0.3Vdc	30±0.5Vdc	60±1Vdc	
	BAT. POLARITY		By internal fuse open						
	OVER TEMPERATURE		Protection type : Shut down o/p voltage, re-power on to recover						
	OUTPUT SHORT		Protection type : Shut down o/p voltage, re-power on to recover						
	OVER LOAD (Typ.)		105 ~ 115% load for 180 sec., 115% ~ 150% load for 10 sec. Protection type : Shut down o/p voltage, re-power on to recover						
	GFCI PROTECTION		Design refer to UL458 (Only for "GFCI" AC socket, by request)		None				
FUNCTION	REMOTE CONTROL DRY CONTACT	Power ON-OFF remote control by front panel dry contact connector (by RELAY) Open : Normal work ; Short : Remote off							
ENVIRON-MENT	WORK TEMP.	-25 ~ +70°C (Refer to "Derating curve")							
	WORKING HUMIDITY	20 ~ 90% RH non-condensing							
	STORAGE TEMP., HUMIDITY	-30 ~ +70°C / -22 ~ +158°F, 10 ~ 95% RH non-condensing							
	VIBRATION	10 ~ 500Hz, 3G 10min./1cycle, 60min. each along X, Y, Z axes							
OTHER	MTBF	281.3K hrs min. Telcordia TR/SR-332 (Bellcore); 85K hrs min. MIL-HDBK-217F (25°C)							
	DIMENSION	210*130*55mm (L*W*H)							
	PACKING	1.3Kg; 8pcs/ 11.4Kg/ 1.74CUFT							

NTS-750 series

MODEL		NTS-750-112 <input type="checkbox"/> NTS-750-124 <input type="checkbox"/> NTS-750-148 <input type="checkbox"/> NTS-750-212 <input type="checkbox"/> NTS-750-224 <input type="checkbox"/> NTS-750-248 <input type="checkbox"/>							
		<input type="checkbox"/> = US, GFCI, UN <input type="checkbox"/> = EU, CN, AU, UK, UN							
OUTPUT	RATED POWER(Continuous)	750W							
	OVER RATED POWER(3 Min.)	862.5W							
	PEAK POWER(10 Sec.)	1125W							
	SURGE POWER(30 Cycles)	1500W							
	AC VOLTAGE	Default setting set at 110VAC 100 / 110 / 115 / 120Vac selectable by DIP S.W	Default setting set at 230VAC 200 / 220 / 230 / 240Vac selectable by DIP S.W						
	FREQUENCY	Default setting set at 60±0.1Hz 50/60Hz selectable by DIP S.W	Default setting set at 50Hz±0.1Hz 50/60Hz selectable by DIP S.W						
	WAVEFORM	Note.1 True sine wave (THD<3%)							
	AC REGULATION	±3.0% at rated input voltage							
FRONT PANEL LED Please refer to section 3.4 of installation manual									
INPUT	BAT. VOLTAGE	12V	24V	48V	12V	24V	48V		
	VOLTAGE RANGE (Typ.)	10 ~ 16.5Vdc	20 ~ 33Vdc	40 ~ 66Vdc	10 ~ 16.5Vdc	20 ~ 33Vdc	40 ~ 66Vdc		
	DC CURRENT (Typ.)	75A	38A	19A	75A	38A	19A		
	NO LOAD DISSIPATION (Typ.)	NON-SAVING MODE	10W	10W	12W	10W	10W	12W	
		SAVING MODE	Default disable, ≤1.2W ~ 1.5W by models @ auto detect AC output load ≤10W will be changed to saving mode						
			1.2W	1.4W	1.5W	1.2W	1.4W	1.5W	
	OFF MODE CURRENT DRAW	≤1mA							
	EFFICIENCY (Typ.)	Note.1	89%	90%	91%	91%	93%	93%	
BATTERY TYPES				Lead Acid or li-ion					
PROTECTION	DC INPUT	FUSE (INTERNAL)		40A*3	40A*2	25A*2	40A*3	40A*2	25A*2
		LOW	ALARM	11±0.3Vdc	22±0.5Vdc	44±1Vdc	11±0.3Vdc	22±0.5Vdc	44±1Vdc
			SHUTDOWN	10±0.3Vdc	20±0.5Vdc	40±1Vdc	10±0.3Vdc	20±0.5Vdc	40±1Vdc
			RESTART	12.5±0.3Vdc	25±0.5Vdc	50±1Vdc	12.5±0.3Vdc	25±0.5Vdc	50±1Vdc
		HIGH	ALARM	15.5±0.3Vdc	31±0.5Vdc	62±1Vdc	15.5±0.3Vdc	31±0.5Vdc	62±1Vdc
			SHUTDOWN	16.5±0.3Vdc	33±0.5Vdc	66±1Vdc	16.5±0.3Vdc	33±0.5Vdc	66±1Vdc
	RESTART		15±0.3Vdc	30±0.5Vdc	60±1Vdc	15±0.3Vdc	30±0.5Vdc	60±1Vdc	
	BAT. POLARITY		By internal fuse open						
	OVER TEMPERATURE		Protection type : Shut down o/p voltage, re-power on to recover						
	OUTPUT SHORT		Protection type : Shut down o/p voltage, re-power on to recover						
	OVER LOAD (Typ.)		105 ~ 115% load for 180 sec., 115% ~ 150% load for 10 sec. Protection type : Shut down o/p voltage, re-power on to recover						
	GFCI PROTECTION		UL458 (Only for "GFCI" AC socket, by request)		None				
FUNCTION	REMOTE CONTROL	CONNECTOR	Power ON-OFF remote control by front panel dry contact connector (by RELAY) Open : Normal work ; Short : Remote off						
		ACCESSORY	Remote controller sold separately, Order No.: IRC1,IRC2,IRC3						
	RS-232 COMMUNICATION		RS-232 ~ RJ11 Type connector						
ENVIRON-MENT	WORK TEMP.	-25 ~ +70°C (Refer to "Derating curve")							
	WORKING HUMIDITY	20 ~ 90% RH non-condensing							
	STORAGE TEMP., HUMIDITY	-30 ~ +70°C / -22 ~ +158°F, 10 ~ 95% RH non-condensing							
	VIBRATION	10 ~ 500Hz, 3G 10min./1cycle, 60min. each along X, Y, Z axes							
OTHER	MTBF	238.6K hrs min. Telcordia TR/SR-332 (Bellcore); 78K hrs min. MIL-HDBK-217F (25°C)							
	DIMENSION	270*158*67mm (L*W*H)							
	PACKING	2.3Kg; 4pcs/ 10.2Kg/ 1.77CUFT							

NTS-1200 series

MODEL		NTS-1200-112 <input type="checkbox"/> NTS-1200-124 <input type="checkbox"/> NTS-1200-148 <input type="checkbox"/> NTS-1200-212 <input type="checkbox"/> NTS-1200-224 <input type="checkbox"/> NTS-1200-248 <input type="checkbox"/>							
		<input type="checkbox"/> = US, GFCI, UN <input type="checkbox"/> = EU, CN, AU, UK, UN							
OUTPUT	RATED POWER(Continuous)	1200W							
	OVER RATED POWER(3 Min.)	1380W							
	PEAK POWER(10 Sec.)	1800W							
	SURGE POWER(30 Cycles)	2000W							
	AC VOLTAGE	Default setting set at 110VAC 100 / 110 / 115 / 120Vac selectable by DIP S.W	Default setting set at 230VAC 200 / 220 / 230 / 240Vac selectable by DIP S.W						
	FREQUENCY	Default setting set at 60±0.1Hz 50/60Hz selectable by DIP S.W	Default setting set at 50Hz±0.1Hz 50/60Hz selectable by DIP S.W						
	WAVEFORM	Note.1 True sine wave (THD<3%)							
	AC REGULATION	±3.0% at rated input voltage							
FRONT PANEL LED Please refer to section 3.4 of installation manual									
INPUT	BAT. VOLTAGE	12V	24V	48V	12V	24V	48V		
	VOLTAGE RANGE (Typ.)	10 ~ 16.5Vdc	20 ~ 33Vdc	40 ~ 66Vdc	10 ~ 16.5Vdc	20 ~ 33Vdc	40 ~ 66Vdc		
	DC CURRENT (Typ.)	120A	60A	30A	120A	60A	30A		
	NO LOAD DISSIPATION (Typ.)	NON-SAVING MODE	15W	25W					
		SAVING MODE	Default disable, auto detect AC output load ≤10W will be changed to saving mode						
			1.2W	1.4W	1.5W	1.2W	1.4W	1.5W	
	OFF MODE CURRENT DRAW	≤1mA							
	EFFICIENCY (Typ.)	Note.1	89%	90%	91%	90%	92%	93%	
BATTERY TYPES				Lead Acid or li-ion					
PROTECTION	DC INPUT	FUSE (INTERNAL)		40A*4	40A*2	25A*2	40A*4	40A*2	25A*2
		LOW	ALARM	11±0.3Vdc	22±0.5Vdc	44±1Vdc	11±0.3Vdc	22±0.5Vdc	44±1Vdc
			SHUTDOWN	10±0.3Vdc	20±0.5Vdc	40±1Vdc	10±0.3Vdc	20±0.5Vdc	40±1Vdc
			RESTART	12.5±0.3Vdc	25±0.5Vdc	50±1Vdc	12.5±0.3Vdc	25±0.5Vdc	50±1Vdc
		HIGH	ALARM	15.5±0.3Vdc	31±0.5Vdc	62±1Vdc	15.5±0.3Vdc	31±0.5Vdc	62±1Vdc
			SHUTDOWN	16.5±0.3Vdc	33±0.5Vdc	66±1Vdc	16.5±0.3Vdc	33±0.5Vdc	66±1Vdc
	RESTART		15±0.3Vdc	30±0.5Vdc	60±1Vdc	15±0.3Vdc	30±0.5Vdc	60±1Vdc	
	BAT. POLARITY		By internal fuse open						
	OVER TEMPERATURE		Protection type : Shut down o/p voltage, re-power on to recover						
	OUTPUT SHORT		Protection type : Shut down o/p voltage, re-power on to recover						
	OVER LOAD (Typ.)		105 ~ 115% load for 180 sec., 115% ~ 150% load for 10 sec. Protection type : Shut down o/p voltage, re-power on to recover						
	CIRCUIT BREAKER		15A		10A				
GFCI PROTECTION		UL458 (Only for "GFCI" AC socket)		None					
FUNCTION	REMOTE CONTROL	CONNECTOR	Power ON-OFF remote control by front panel dry contact connector (by RELAY) Open : Normal work ; Short : Remote off						
		ACCESSORY	Remote controller sold separately, Order No.: IRC1,IRC2,IRC3						
	RS-232 COMMUNICATION		RS-232 ~ RJ11 Type connector						
ENVIRON-MENT	WORK TEMP.	-25 ~ +70°C (Refer to "Derating curve")							
	WORKING HUMIDITY	20 ~ 90% RH non-condensing							
	STORAGE TEMP., HUMIDITY	-30 ~ +70°C / -22 ~ +158°F, 10 ~ 95% RH non-condensing							
	VIBRATION	10 ~ 500Hz, 3G 10min./1cycle, 60min. each along X, Y, Z axes							
OTHER	MTBF	198.9K hrs min. Telcordia TR/SR-332 (Bellcore); 62.0K hrs min. MIL-HDBK-217F (25°C)							
	DIMENSION	333*184*70mm (L*W*H)							
	PACKING	3.3Kg; 2pcs/ 7.6Kg/ 1.16CUFT							

NTS-1700 series

MODEL		NTS-1700-112 <input type="checkbox"/> NTS-1700-124 <input type="checkbox"/> NTS-1700-148 <input type="checkbox"/>			NTS-1700-212 <input type="checkbox"/> NTS-1700-224 <input type="checkbox"/> NTS-1700-248 <input type="checkbox"/>				
		<input type="checkbox"/> = US, GFCI, UN			<input type="checkbox"/> = EU, CN, AU, UK, UN				
OUTPUT	RATED POWER(Continuous)	1500W			1700W				
	OVER RATED POWER(3 Min.)	1750W			2000W				
	PEAK POWER(10 Sec.)	2250W			2550W				
	SURGE POWER(30 Cycles)	3000W			3400W				
	AC VOLTAGE	Default setting set at 110VAC 100 / 110 / 115 / 120Vac selectable by DIP S.W			Default setting set at 230VAC 200 / 220 / 230 / 240Vac selectable by DIP S.W				
	FREQUENCY	Default setting set at 60±0.1Hz 50/60Hz selectable by DIP S.W			Default setting set at 50Hz±0.1Hz 50/60Hz selectable by DIP S.W				
	WAVEFORM	Note.1 True sine wave (THD<3%)							
AC REGULATION	±3.0% at rated input voltage								
FRONT PANEL LED	Please refer to section 3.4 of installation manual								
INPUT	BAT. VOLTAGE	12V	24V	48V	12V	24V	48V		
	VOLTAGE RANGE (Typ.)	10 ~ 16.5Vdc	20 ~ 33Vdc	40 ~ 66Vdc	10 ~ 16.5Vdc	20 ~ 33Vdc	40 ~ 66Vdc		
	DC CURRENT (Typ.)	150A	75A	37.5A	170A	85A	42.5A		
	NO LOAD DISSIPATION (Typ.)	Default disable, ≤ 1.2W ~ 1.5W by models @ auto detect AC output load ≤ 10W will be changed to saving mode							
	SAVING MODE (Typ.)	1.2W	1.4W	1.5W	1.2W	1.4W	1.5W		
	OFF MODE CURRENT DRAW	≤ 1mA							
	EFFICIENCY (Typ.)	Note.1 89%		90%	91%	90%	92%	93%	
BATTERY TYPES	Lead Acid or li-ion								
PROTECTION	DC INPUT	FUSE (INTERNAL)	40A*5	30A*3	30A*2	40A*5	30A*3	30A*2	
		LOW	ALARM	11±0.3Vdc	22±0.5Vdc	44±1Vdc	11±0.3Vdc	22±0.5Vdc	44±1Vdc
			SHUTDOWN	10±0.3Vdc	20±0.5Vdc	40±1Vdc	10±0.3Vdc	20±0.5Vdc	40±1Vdc
			RESTART	12.5±0.3Vdc	25±0.5Vdc	50±1Vdc	12.5±0.3Vdc	25±0.5Vdc	50±1Vdc
		HIGH	ALARM	15.5±0.3Vdc	31±0.5Vdc	62±1Vdc	15.5±0.3Vdc	31±0.5Vdc	62±1Vdc
	SHUTDOWN		16.5±0.3Vdc	33±0.5Vdc	66±1Vdc	16.5±0.3Vdc	33±0.5Vdc	66±1Vdc	
	RESTART		15±0.3Vdc	30±0.5Vdc	60±1Vdc	15±0.3Vdc	30±0.5Vdc	60±1Vdc	
	BAT. POLARITY	By internal fuse open							
	AC OUTPUT	OVER TEMPERATURE	Protection type : Shut down o/p voltage, re-power on to recover						
		OUTPUT SHORT	Protection type : Shut down o/p voltage, re-power on to recover						
OVER LOAD (Typ.)		105 ~ 115% load for 180 sec., 115% ~ 150% load for 10 sec. Protection type : Shut down o/p voltage, re-power on to recover							
CIRCUIT BREAKER(GFCI)		15A			10A				
GFCI PROTECTION		UL458 (Only for "GFCI" AC socket) None							
FUNCTION	REMOTE CONTROL	CONNECTOR	Power ON-OFF remote control by front panel dry contact connector (by RELAY) Open : Normal work ; Short : Remote off						
		ACCESSORY	Remote controller sold separately, Order No.: IRC1,IRC2,IRC3						
	RS-232 COMMUNICATION	RS-232 ~ RJ11 Type connector							
ENVIRON- MENT	WORK TEMP.	-20 ~ +70°C (Refer to "Derating curve")							
	WORKING HUMIDITY	20 ~ 90% RH non-condensing							
	STORAGE TEMP., HUMIDITY	-30 ~ +70°C / -22 ~ +158°F, 10 ~ 95% RH non-condensing							
	VIBRATION	10 ~ 500Hz, 3G 10min./1cycle, 60min. each along X, Y, Z axes							
OTHER	MTBF	475.5K hrs min. Telcordia TR/SR-332 (Bellcore);		46.2K hrs min. MIL-HDBK-217F (25°C)					
	DIMENSION	400*184*70mm (L*W*H)							
	PACKING	4.63Kg; 2pcs/ 12Kg/ 1.76CUFT							

NTS-2200 series

MODEL		NTS-2200-112 <input type="checkbox"/> NTS-2200-124 <input type="checkbox"/> NTS-2200-148 <input type="checkbox"/>			NTS-2200-212 <input type="checkbox"/> NTS-2200-224 <input type="checkbox"/> NTS-2200-248 <input type="checkbox"/>				
		<input type="checkbox"/> = US, UN, TB			<input type="checkbox"/> = EU, CN, AU, UK, UN, TB				
OUTPUT	RATED POWER(Continuous)	2200W							
	OVER RATED POWER(3 Min.)	2530W							
	PEAK POWER(10 Sec.)	3300W							
	SURGE POWER(30 Cycles)	4400W							
	AC VOLTAGE	Default setting set at 110VAC 100 / 110 / 115 / 120Vac selectable by DIP S.W			Default setting set at 230VAC 200 / 220 / 230 / 240Vac selectable by DIP S.W				
	FREQUENCY	Default setting set at 60±0.1Hz 50/60Hz selectable by DIP S.W			Default setting set at 50Hz±0.1Hz 50/60Hz selectable by DIP S.W				
	WAVEFORM	Note.1 True sine wave (THD<3%)							
AC REGULATION	±3.0% at rated input voltage								
FRONT PANEL LED	Please refer to section 3.4 of installation manual								
INPUT	BAT. VOLTAGE	12V	24V	48V	12V	24V	48V		
	VOLTAGE RANGE (Typ.)	10 ~ 16.5Vdc	20 ~ 33Vdc	40 ~ 66Vdc	10 ~ 16.5Vdc	20 ~ 33Vdc	40 ~ 66Vdc		
	DC CURRENT (Typ.)	250A	120A	60A	250A	120A	60A		
	NO LOAD DISSIPATION (Typ.)	Default disable, auto detect AC output load ≤ 10W will be changed to saving mode							
	SAVING MODE (Typ.)	1.7W							
	OFF MODE CURRENT DRAW	≤ 2mA							
	EFFICIENCY (Typ.)	Note.1 89%		90%	91%	90%	92%	93%	
BATTERY TYPES	Lead Acid or li-ion								
PROTECTION	DC INPUT	FUSE (INTERNAL)	40A*8	40A*4	25A*4	40A*8	40A*4	25A*4	
		LOW	ALARM	11±0.3Vdc	22±0.5Vdc	44±1Vdc	11±0.3Vdc	22±0.5Vdc	44±1Vdc
			SHUTDOWN	10±0.3Vdc	20±0.5Vdc	40±1Vdc	10±0.3Vdc	20±0.5Vdc	40±1Vdc
			RESTART	12.5±0.3Vdc	25±0.5Vdc	50±1Vdc	12.5±0.3Vdc	25±0.5Vdc	50±1Vdc
		HIGH	ALARM	15.5±0.3Vdc	31±0.5Vdc	62±1Vdc	15.5±0.3Vdc	31±0.5Vdc	62±1Vdc
	SHUTDOWN		16.5±0.3Vdc	33±0.5Vdc	66±1Vdc	16.5±0.3Vdc	33±0.5Vdc	66±1Vdc	
	RESTART		15±0.3Vdc	30±0.5Vdc	60±1Vdc	15±0.3Vdc	30±0.5Vdc	60±1Vdc	
	BAT. POLARITY	By internal fuse open							
	AC OUTPUT	OVER TEMPERATURE	Protection type : Shut down o/p voltage, re-power on to recover						
		OUTPUT SHORT	Protection type : Shut down o/p voltage, re-power on to recover						
OVER LOAD (Typ.)		105 ~ 115% load for 180 sec., 115% ~ 150% load for 10 sec. Protection type : Shut down o/p voltage, re-power on to recover							
CIRCUIT BREAKER		25A (Only for "TB" AC socket)			None				
TB TYPE		UL458 (Only for "TB" AC socket)			None				
FUNCTION	REMOTE CONTROL	CONNECTOR	Power ON-OFF remote control by front panel dry contact connector (by RELAY) Open : Normal work ; Short : Remote off						
		ACCESSORY	Remote controller sold separately, Order No.: IRC1,IRC2,IRC3						
	RS-232 COMMUNICATION	RS-232 ~ RJ11 Type connector							
ENVIRON- MENT	WORK TEMP.	-25 ~ +70°C (Refer to "Derating curve")							
	WORKING HUMIDITY	20 ~ 90% RH non-condensing							
	STORAGE TEMP., HUMIDITY	-30 ~ +70°C / -22 ~ +158°F, 10 ~ 95% RH non-condensing							
	VIBRATION	10 ~ 500Hz, 3G 10min./1cycle, 60min. each along X, Y, Z axes							
OTHER	MTBF	364.7K hrs min. Telcordia TR/SR-332 (Bellcore);		34.9K hrs min. MIL-HDBK-217F (25°C)					
	DIMENSION	420*270*98mm (L*W*H)							
	PACKING	8.6Kg; 1pcs/ 10.4Kg/ 1.39CUFT							

NTS-3200 series

MODEL		NTS-3200-112 <input type="checkbox"/> NTS-3200-124 <input type="checkbox"/> NTS-3200-148 <input type="checkbox"/>			NTS-3200-212 <input type="checkbox"/> NTS-3200-224 <input type="checkbox"/> NTS-3200-248 <input type="checkbox"/>				
		<input type="checkbox"/> = US, UN, TB			<input type="checkbox"/> = EU, CN, AU, UK, UN, TB				
OUTPUT	RATED POWER(Continuous)	3200W			3200W				
	OVER RATED POWER(3 Min.)	3500W			3680W				
	PEAK POWER(10 Sec.)	4500W			4800W				
	SURGE POWER(30 Cycles)	6000W			6400W				
	AC VOLTAGE	Default setting set at 110VAC 100 / 110 / 115 / 120Vac selectable by DIP S.W			Default setting set at 230VAC 200 / 220 / 230 / 240Vac selectable by DIP S.W				
	FREQUENCY	Default setting set at 60±0.1Hz 50/60Hz selectable by DIP S.W			Default setting set at 50Hz±0.1Hz 50/60Hz selectable by DIP S.W				
	WAVEFORM	Note.1 True sine wave (THD<3%)							
	AC REGULATION	±3.0% at rated input voltage							
FRONT PANEL LED Please refer to section 3.4 of installation manual									
INPUT	BAT. VOLTAGE	12V	24V	48V	12V	24V	48V		
	VOLTAGE RANGE (Typ.)	10 ~ 16.5Vdc	20 ~ 33Vdc	40 ~ 66Vdc	10 ~ 16.5Vdc	20 ~ 33Vdc	40 ~ 66Vdc		
	DC CURRENT (Typ.)	300A	150A	75A	320A	160A	80A		
	NO LOAD DISSIPATION (Typ.)	Default disable, auto detec AC output load ≤10W will be changed to saving mode 1.7W							
	OFF MODE CURRENT DRAW	≤2mA							
	EFFICIENCY (Typ.)	Note.1 89%		90%	91%	90%	92%	93%	
	BATTERY TYPES		Lead Acid or li-ion						
	PROTECTION	DC INPUT	FUSE (INTERNAL)		40A*12	40A*6	25A*6	40A*12	40A*6
LOW			ALARM	11±0.3Vdc	22±0.5Vdc	44±1Vdc	11±0.3Vdc	22±0.5Vdc	44±1Vdc
			SHUTDOWN	10±0.3Vdc	20±0.5Vdc	40±1Vdc	10±0.3Vdc	20±0.5Vdc	40±1Vdc
			RESTART	12.5±0.3Vdc	25±0.5Vdc	50±1Vdc	12.5±0.3Vdc	25±0.5Vdc	50±1Vdc
HIGH			ALARM	15.5±0.3Vdc	31±0.5Vdc	62±1Vdc	15.5±0.3Vdc	31±0.5Vdc	62±1Vdc
			SHUTDOWN	16.5±0.3Vdc	33±0.5Vdc	66±1Vdc	16.5±0.3Vdc	33±0.5Vdc	66±1Vdc
		RESTART	15±0.3Vdc	30±0.5Vdc	60±1Vdc	15±0.3Vdc	30±0.5Vdc	60±1Vdc	
BAT. POLARITY		By internal fuse open							
OVER TEMPERATURE		Protection type : Shut down o/p voltage, re-power on to recover							
OUTPUT SHORT		Protection type : Shut down o/p voltage, re-power on to recover							
OVER LOAD (Typ.)		105 ~ 115% load for 180 sec., 115% ~ 150% load for 10 sec. Protection type : Shut down o/p voltage, re-power on to recover							
CIRCUIT BREAKER		30A (Only for "TB" AC socket)			None				
TB TYPE		UL458 (Only for "TB" AC socket)			None				
FUNCTION	REMOTE CONTROL	CONNECTOR	Power ON-OFF remote control by front panel dry contact connector (by RELAY) Open : Normal work ; Short : Remote off						
		ACCESSORY	Remote controller sold separately, Order No.: IRC1,IRC2,IRC3						
	RS-232 COMMUNICATION	RS-232 ~ RJ11 Type connector							
ENVIRON- MENT	WORK TEMP.	-25 ~ +70°C (Refer to "Derating curve")							
	WORKING HUMIDITY	20 ~ 90% RH non-condensing							
	STORAGE TEMP., HUMIDITY	-30 ~ +70°C / -22 ~ +158°F, 10 ~ 95% RH non-condensing							
	VIBRATION	10 ~ 500Hz, 3G 10min./1cycle, 60min. each along X, Y, Z axes							
OTHER	MTBF	336.9K hrs min. Telcordia TR/SR-332 (Bellcore); 30.5K hrs min. MIL-HDBK-217F (25°C)							
	DIMENSION	420*270*98mm (L*W*H)							
	PACKING	8.6Kg; 1pcs/ 10.4Kg/ 1.39CUFT							

NTU-1200 series (Built-in UPS function)

MODEL		NTU-1200-112 <input type="checkbox"/> NTU-1200-124 <input type="checkbox"/> NTU-1200-148 <input type="checkbox"/>			NTU-1200-212 <input type="checkbox"/> NTU-1200-224 <input type="checkbox"/> NTU-1200-248 <input type="checkbox"/>				
		<input type="checkbox"/> = US, GFCI, UN			<input type="checkbox"/> = EU, CN, AU, UK, UN				
OUTPUT	RATED POWER(Continuous)	1200W							
	OVER RATED POWER(3 Min.)	1380W							
	PEAK POWER(10 Sec.)	1800W							
	SURGE POWER(30 Cycles)	2000W							
	AC VOLTAGE	Default setting set at 110VAC 100 / 110 / 115 / 120Vac selectable by DIP S.W			Default setting set at 230VAC 200 / 220 / 230 / 240Vac selectable by DIP S.W				
	FREQUENCY	Default setting set at 60±0.1Hz 50/60Hz selectable by DIP S.W			Default setting set at 50Hz±0.1Hz 50/60Hz selectable by DIP S.W				
	WAVEFORM	Note.1 True sine wave (THD<3%)							
	AC REGULATION	±3.0% at rated input voltage							
FRONT PANEL LED Please refer to section 3.4 of installation manual									
INPUT	BAT. VOLTAGE	12V	24V	48V	12V	24V	48V		
	VOLTAGE RANGE (Typ.)	10 ~ 16.5Vdc	20 ~ 33Vdc	40 ~ 66Vdc	10 ~ 16.5Vdc	20 ~ 33Vdc	40 ~ 66Vdc		
	DC CURRENT (Typ.)	120A	60A	30A	120A	60A	30A		
	NO LOAD DISSIPATION (Typ.)	NON-SAVING MODE 15W		SAVING MODE 25W		Default disable, auto detec AC output load ≤10W will be changed to saving mode <8W			
	OFF MODE CURRENT DRAW	≤1mA							
	EFFICIENCY (Typ.)	Note.1 89%		90%	91%	90%	92%	93%	
	BATTERY TYPES		Lead Acid or li-ion						
	PROTECTION	DC INPUT	FUSE (INTERNAL)		40A*4	40A*2	25A*2	40A*4	40A*2
LOW			ALARM	11±0.3Vdc	22±0.5Vdc	44±1Vdc	11±0.3Vdc	22±0.5Vdc	44±1Vdc
			SHUTDOWN	10±0.3Vdc	20±0.5Vdc	40±1Vdc	10±0.3Vdc	20±0.5Vdc	40±1Vdc
			RESTART	12.5±0.3Vdc	25±0.5Vdc	50±1Vdc	12.5±0.3Vdc	25±0.5Vdc	50±1Vdc
HIGH			ALARM	15.5±0.3Vdc	31±0.5Vdc	62±1Vdc	15.5±0.3Vdc	31±0.5Vdc	62±1Vdc
			SHUTDOWN	16.5±0.3Vdc	33±0.5Vdc	66±1Vdc	16.5±0.3Vdc	33±0.5Vdc	66±1Vdc
		RESTART	15±0.3Vdc	30±0.5Vdc	60±1Vdc	15±0.3Vdc	30±0.5Vdc	60±1Vdc	
BAT. POLARITY		By internal fuse open							
OVER TEMPERATURE		Protection type : Shut down o/p voltage, re-power on to recover							
OUTPUT SHORT		Protection type : Shut down o/p voltage, re-power on to recover							
OVER LOAD (Typ.)		105 ~ 115% load for 180 sec., 115% ~ 150% load for 10 sec. Protection type : Shut down o/p voltage, re-power on to recover							
CIRCUIT BREAKER		15A			10A				
GFCI PROTECTION		UL458 (Only for "GFCI" AC socket) None							
FUNCTION	REMOTE CONTROL	CONNECTOR	Power ON-OFF remote control by front panel dry contact connector (by RELAY) Open : Normal work ; Short : Remote off						
		ACCESSORY	Remote controller sold separately, Order No.: IRC1,IRC2,IRC3						
	RS-232 COMMUNICATION	RS-232 ~ RJ11 Type connector							
AC UPS MODE	AC INPUT RANGE	100/110/115/120Vac ±16%, recover ±13%			200/220/230/240Vac ±16%, recover ±13%				
	FREQUENCY RANGE	45 ~ 65Hz							
	TRANSFER TIME (Typ.)	10ms inverter → AC by pass							
ENVIRON- MENT	WORK TEMP.	-25 ~ +70°C (Refer to "Derating curve")							
	WORKING HUMIDITY	20 ~ 90% RH non-condensing							
	STORAGE TEMP., HUMIDITY	-30 ~ +70°C / -22 ~ +158°F, 10 ~ 95% RH non-condensing							
	VIBRATION	10 ~ 500Hz, 3G 10min./1cycle, 60min. each along X, Y, Z axes							
OTHER	MTBF	166.3K hrs min. Telcordia TR/SR-332 (Bellcore); 58.3K hrs min. MIL-HDBK-217F (25°C)							
	DIMENSION	333*184*70mm (L*W*H)							
	PACKING	3.3Kg; 2pcs/ 7.6Kg/ 1.16CUFT							

NTU-1700 series (Built-in UPS function)

MODEL		NTU-1700-112 <input type="checkbox"/> NTU-1700-124 <input type="checkbox"/> NTU-1700-148 <input type="checkbox"/>		NTU-1700-212 <input type="checkbox"/> NTU-1700-224 <input type="checkbox"/> NTU-1700-248 <input type="checkbox"/>					
		<input type="checkbox"/> = US, GFCI, UN		<input type="checkbox"/> = EU, CN, AU, UK, UN					
OUTPUT	RATED POWER(Continuous)	1500W		1700W					
	OVER RATED POWER(3 Min.)	1750W		2000W					
	PEAK POWER(10 Sec.)	2250W		2550W					
	SURGE POWER(30 Cycles)	3000W		3400W					
	AC VOLTAGE	Default setting set at 110VAC 100 / 110 / 115 / 120Vac selectable by DIP S.W		Default setting set at 230VAC 200 / 220 / 230 / 240Vac selectable by DIP S.W					
	FREQUENCY	Default setting set at 60 ± 0.1Hz 50/60Hz selectable by DIP S.W		Default setting set at 50Hz ± 0.1Hz 50/60Hz selectable by DIP S.W					
	WAVEFORM	Note.1 True sine wave (THD<3%)							
	AC REGULATION	± 3.0% at rated input voltage							
FRONT PANEL LED Please refer to section 3.4 of installation manual									
INPUT	BAT. VOLTAGE	12V	24V	48V	12V	24V	48V		
	VOLTAGE RANGE (Typ.)	10 ~ 16.5Vdc	20 ~ 33Vdc	40 ~ 66Vdc	10 ~ 16.5Vdc	20 ~ 33Vdc	40 ~ 66Vdc		
	DC CURRENT (Typ.)	150A	75A	37.5A	170A	85A	42.5A		
	POWER SAVING MODE	≤ 1.2W@standby saving, mode when AC output load ≤ 10W, auto wake up when AC output load ≥ 15W							
	OFF MODE CURRENT DRAW	≤ 1mA							
	EFFICIENCY (Typ.)	Note.1 89%		90%	91%	90%	92%	93%	
	BATTERY TYPES		Lead Acid or li-ion						
PROTECTION	DC INPUT	FUSE (INTERNAL)		40A*5	30A*3	30A*2	40A*5	30A*3	30A*2
		LOW	ALARM	11 ± 0.3Vdc	22 ± 0.5Vdc	44 ± 1Vdc	11 ± 0.3Vdc	22 ± 0.5Vdc	44 ± 1Vdc
			SHUTDOWN	10 ± 0.3Vdc	20 ± 0.5Vdc	40 ± 1Vdc	10 ± 0.3Vdc	20 ± 0.5Vdc	40 ± 1Vdc
			RESTART	12.5 ± 0.3Vdc	25 ± 0.5Vdc	50 ± 1Vdc	12.5 ± 0.3Vdc	25 ± 0.5Vdc	50 ± 1Vdc
		HIGH	ALARM	15.5 ± 0.3Vdc	31 ± 0.5Vdc	62 ± 1Vdc	15.5 ± 0.3Vdc	31 ± 0.5Vdc	62 ± 1Vdc
			SHUTDOWN	16.5 ± 0.3Vdc	33 ± 0.5Vdc	66 ± 1Vdc	16.5 ± 0.3Vdc	33 ± 0.5Vdc	66 ± 1Vdc
			RESTART	15 ± 0.3Vdc	30 ± 0.5Vdc	60 ± 1Vdc	15 ± 0.3Vdc	30 ± 0.5Vdc	60 ± 1Vdc
	BAT. POLARITY		By internal fuse open						
	AC OUTPUT	OVER TEMPERATURE		Protection type : Shut down o/p voltage, re-power on to recover					
		OUTPUT SHORT		Protection type : Shut down o/p voltage, re-power on to recover					
		OVER LOAD (Typ.)		105 ~ 115% load for 180 sec., 115% ~ 150% load for 10 sec.					
		CIRCUIT BREAKER(GFCI)		15A			10A		
		GFCI PROTECTION		UL458 (Only for "GFCI" AC socket) None					
	FUNCTION	REMOTE CONTROL	CONNECTOR	Power ON-OFF remote control by front panel dry contact connector (by RELAY) Open : Normal work ; Short : Remote off					
ACCESSORY			Remote controller sold separately, Order No.: IRC1,IRC2,IRC3						
RS-232 COMMUNICATION		RS-232 ~ RJ11 Type connector							
AC UPS MODE	AC INPUT RANGE		100/110/115/120Vac ± 16%, recover ± 13%		200/220/230/240Vac ± 16%, recover ± 13%				
	FREQUENCY RANGE		45 ~ 65Hz						
	TRASFER TIME (Typ.)		10ms inverter → AC by pass						
ENVIRON- MENT	WORK TEMP.		-20 ~ +70°C (Refer to "Derating curve")						
	WORKING HUMIDITY		20 ~ 90% RH non-condensing						
	STORAGE TEMP., HUMIDITY		-30 ~ +70°C / -22 ~ +158°F, 10 ~ 95% RH non-condensing						
	VIBRATION		10 ~ 500Hz, 3G 10min./1cycle, 60min. each along X, Y, Z axes						
OTHER	MTBF		421.9K hrs min. Telcordia TR/SR-332 (Bellcore);		45.3K hrs min. MIL-HDBK-217F (25°C)				
	DIMENSION		400*184*70mm (L*W*H)						
	PACKING		4.63Kg; 2pcs/ 12Kg/ 1.76CUFT						

NTU-2200 series (Built-in UPS function)

MODEL		NTU-2200-112 <input type="checkbox"/> NTU-2200-124 <input type="checkbox"/> NTU-2200-148 <input type="checkbox"/>		NTU-2200-212 <input type="checkbox"/> NTU-2200-224 <input type="checkbox"/> NTU-2200-248 <input type="checkbox"/>						
		<input type="checkbox"/> = US, UN, TB		<input type="checkbox"/> = EU, CN, AU, UK, UN, TB						
OUTPUT	RATED POWER(Continuous)	2200W								
	OVER RATED POWER(3 Min.)	2530W								
	PEAK POWER(10 Sec.)	3300W								
	SURGE POWER(30 Cycles)	4400W								
	AC VOLTAGE	Default setting set at 110VAC 100 / 110 / 115 / 120Vac selectable by DIP S.W		Default setting set at 230VAC 200 / 220 / 230 / 240Vac selectable by DIP S.W						
	FREQUENCY	Default setting set at 60 ± 0.1Hz 50/60Hz selectable by DIP S.W		Default setting set at 50Hz ± 0.1Hz 50/60Hz selectable by DIP S.W						
	WAVEFORM	Note.1 True sine wave (THD<3%)								
	AC REGULATION	± 3.0% at rated input voltage								
FRONT PANEL LED Please refer to section 3.4 of installation manual										
INPUT	BAT. VOLTAGE	12V	24V	48V	12V	24V	48V			
	VOLTAGE RANGE (Typ.)	10 ~ 16.5Vdc	20 ~ 33Vdc	40 ~ 66Vdc	10 ~ 16.5Vdc	20 ~ 33Vdc	40 ~ 66Vdc			
	DC CURRENT (Typ.)	250A	120A	60A	250A	120A	60A			
	NO LOAD DISSIPATION (Typ.)	Default disable, auto detec AC output load ≤ 10W will be changed to saving mode								
	SAVING MODE	15W								
	OFF MODE CURRENT DRAW	≤ 2mA								
	EFFICIENCY (Typ.)	Note.1 89%		90%	91%	90%	92%	93%		
	BATTERY TYPES		Lead Acid or li-ion							
	PROTECTION	DC INPUT	FUSE (INTERNAL)		40A*8	40A*4	25A*4	40A*8	40A*4	25A*4
			LOW	ALARM	11 ± 0.3Vdc	22 ± 0.5Vdc	44 ± 1Vdc	11 ± 0.3Vdc	22 ± 0.5Vdc	44 ± 1Vdc
SHUTDOWN				10 ± 0.3Vdc	20 ± 0.5Vdc	40 ± 1Vdc	10 ± 0.3Vdc	20 ± 0.5Vdc	40 ± 1Vdc	
RESTART				12.5 ± 0.3Vdc	25 ± 0.5Vdc	50 ± 1Vdc	12.5 ± 0.3Vdc	25 ± 0.5Vdc	50 ± 1Vdc	
HIGH			ALARM	15.5 ± 0.3Vdc	31 ± 0.5Vdc	62 ± 1Vdc	15.5 ± 0.3Vdc	31 ± 0.5Vdc	62 ± 1Vdc	
			SHUTDOWN	16.5 ± 0.3Vdc	33 ± 0.5Vdc	66 ± 1Vdc	16.5 ± 0.3Vdc	33 ± 0.5Vdc	66 ± 1Vdc	
			RESTART	15 ± 0.3Vdc	30 ± 0.5Vdc	60 ± 1Vdc	15 ± 0.3Vdc	30 ± 0.5Vdc	60 ± 1Vdc	
BAT. POLARITY		By internal fuse open								
AC OUTPUT		OVER TEMPERATURE		Protection type : Shut down o/p voltage, re-power on to recover						
		OUTPUT SHORT		Protection type : Shut down o/p voltage, re-power on to recover						
		OVER LOAD (Typ.)		105 ~ 115% load for 180 sec., 115% ~ 150% load for 10 sec.						
		CIRCUIT BREAKER		25A			15A			
		TB TYPE		UL458 (Only for "TB" AC socket)			None			
FUNCTION		REMOTE CONTROL	CONNECTOR	Power ON-OFF remote control by front panel dry contact connector (by RELAY) Open : Normal work ; Short : Remote off						
	ACCESSORY		Remote controller sold separately, Order No.: IRC1,IRC2,IRC3							
	RS-232 COMMUNICATION		RS-232 ~ RJ11 Type connector							
AC UPS MODE	AC INPUT RANGE		100/110/115/120Vac ± 16%, recover ± 13%		200/220/230/240Vac ± 16%, recover ± 13%					
	FREQUENCY RANGE		45 ~ 65Hz							
	TRASFER TIME (Typ.)		10ms inverter → AC by pass							
ENVIRON- MENT	WORK TEMP.		-25 ~ +70°C (Refer to "Derating curve")							
	WORKING HUMIDITY		20 ~ 90% RH non-condensing							
	STORAGE TEMP., HUMIDITY		-30 ~ +70°C / -22 ~ +158°F, 10 ~ 95% RH non-condensing							
	VIBRATION		10 ~ 500Hz, 3G 10min./1cycle, 60min. each along X, Y, Z axes							
OTHER	MTBF		344.9K hrs min. Telcordia TR/SR-332 (Bellcore);		34.8K hrs min. MIL-HDBK-217F (25°C)					
	DIMENSION		420*270*98mm (L*W*H)							
	PACKING		8.6Kg; 1pcs/ 10.4Kg/ 1.39CUFT							

NTU-3200 series (Built-in UPS function)

MODEL		NTU-3200-112 <input type="checkbox"/> NTU-3200-124 <input type="checkbox"/> NTU-3200-148 <input type="checkbox"/>			NTU-3200-212 <input type="checkbox"/> NTU-3200-224 <input type="checkbox"/> NTU-3200-248 <input type="checkbox"/>				
		<input type="checkbox"/> = US, UN, TB			<input type="checkbox"/> = EU, CN, AU, UK, UN, TB				
OUTPUT	RATED POWER(Continuous)	3000W			3200W				
	OVER RATED POWER(3 Min.)	3500W			3680W				
	PEAK POWER(10 Sec.)	4500W			4800W				
	SURGE POWER(30 Cycles)	6000W			6400W				
	AC VOLTAGE	Default setting set at 110VAC 100 / 110 / 115 / 120Vac selectable by DIP S.W			Default setting set at 230VAC 200 / 220 / 230 / 240Vac selectable by DIP S.W				
	FREQUENCY	Default setting set at 60±0.1Hz 50/60Hz selectable by DIP S.W			Default setting set at 50Hz±0.1Hz 50/60Hz selectable by DIP S.W				
	WAVEFORM <small>Note.1</small>	True sine wave (THD<3%)							
	AC REGULATION	±3.0% at rated input voltage							
	FRONT PANEL LED	Please refer to section 3.4 of installation manual							
INPUT	BAT. VOLTAGE	12V	24V	48V	12V	24V	48V		
	VOLTAGE RANGE (Typ.)	10 ~ 16.5Vdc	20 ~ 33Vdc	40 ~ 66Vdc	10 ~ 16.5Vdc	20 ~ 33Vdc	40 ~ 66Vdc		
	DC CURRENT (Typ.)	300A	150A	75A	320A	160A	80A		
	NO LOAD DISSIPATION (Typ.)	Default disable, auto detec AC output load ≤10W will be changed to saving mode							
	SAVING MODE (Typ.)	15W							
	OFF MODE CURRENT DRAW	≤2mA							
	EFFICIENCY (Typ.) <small>Note.1</small>	89%	90%	91%	90%	92%	93%		
	BATTERY TYPES	Lead Acid or li-ion							
PROTECTION	DC INPUT	FUSE (INTERNAL)	40A*12	40A*6	25A*6	40A*12	40A*6	25A*6	
		LOW	ALARM	11±0.3Vdc	22±0.5Vdc	44±1Vdc	11±0.3Vdc	22±0.5Vdc	44±1Vdc
			SHUTDOWN	10±0.3Vdc	20±0.5Vdc	40±1Vdc	10±0.3Vdc	20±0.5Vdc	40±1Vdc
			RESTART	12.5±0.3Vdc	25±0.5Vdc	50±1Vdc	12.5±0.3Vdc	25±0.5Vdc	50±1Vdc
		HIGH	ALARM	15.5±0.3Vdc	31±0.5Vdc	62±1Vdc	15.5±0.3Vdc	31±0.5Vdc	62±1Vdc
			SHUTDOWN	16.5±0.3Vdc	33±0.5Vdc	66±1Vdc	16.5±0.3Vdc	33±0.5Vdc	66±1Vdc
			RESTART	15±0.3Vdc	30±0.5Vdc	60±1Vdc	15±0.3Vdc	30±0.5Vdc	60±1Vdc
		BAT. POLARITY	By internal fuse open						
		AC OUTPUT	OVER TEMPERATURE	Protection type : Shut down o/p voltage, re-power on to recover					
	OUTPUT SHORT		Protection type : Shut down o/p voltage, re-power on to recover						
	OVER LOAD (Typ.)		105 ~ 115% load for 180 sec., 115% ~ 150% load for 10 sec.						
			Protection type : Shut down o/p voltage, re-power on to recover						
	CIRCUIT BREAKER		30A			16A			
	TB TYPE		UL458 (Only for "TB" AC socket)			None			
	FUNCTION	REMOTE CONTROL	CONNECTOR	Power ON-OFF remote control by front panel dry contact connector (by RELAY) Open : Normal work ; Short : Remote off					
ACCESSORY			Remote controller sold separately, Order No.: IRC1,IRC2,IRC3						
RS-232 COMMUNICATION		RS-232 ~ RJ11 Type connector							
AC UPS MODE	AC INPUT RANGE	100/110/115/120Vac±16%, recover±13%			200/220/230/240Vac±16%, recover±13%				
	FREQUENCY RANGE	45 ~ 65Hz							
	TRASFER TIME (Typ.)	10ms inverter → AC by pass							
ENVIRON- MENT	WORK TEMP.	-25 ~ +70°C (Refer to "Derating curve")							
	WORKING HUMIDITY	20 ~ 90% RH non-condensing							
	STORAGE TEMP., HUMIDITY	-30 ~ +70°C / -22 ~ +158°F, 10 ~ 95% RH non-condensing							
	VIBRATION	10 ~ 500Hz, 3G 10min./1cycle, 60min. each along X, Y, Z axes							
OTHER	MTBF	319.3K hrs min. Telcordia TR/SR-332 (Bellcore); 30.3K hrs min. MIL-HDBK-217F (25°C)							
	DIMENSION	420*270*98mm (L*W*H)							
	PACKING	8.6Kg; 1pcs/ 10.4Kg/ 1.39CUFT							

2.4 Safety Overview

Enclosure type		Socket type							
		TYPE-US	TYPE-GFCI	TYPE-UN	TYPE-EU	TYPE-CN	TYPE-AU	TYPE-UK	TYPE-TB
		In Stock	By request	In Stock	In Stock	In Stock	By request	By request	In Stock
		USA	USA	UNIVERSAL	EUROPE	CHINA	AUSTRALIA	U.K	UNIVERSAL
110Vac	NTS-300								
	NTS-450								
	NTS-750								
	NTS/NTU-1200								
	NTS/NTU-1700								
	NTS/NTU-2200								
	NTS/NTU-3200								
220Vac	NTS-300								
	NTS-450								
	NTS-750								
	NTS/NTU-1200								
	NTS/NTU-1700								
	NTS/NTU-2200								
	NTS/NTU-3200								

PCB type						
110Vac	NTS-250P					
	NTS-400P					
220Vac	NTS-250P					
	NTS-400P					

2.5 Derating curve

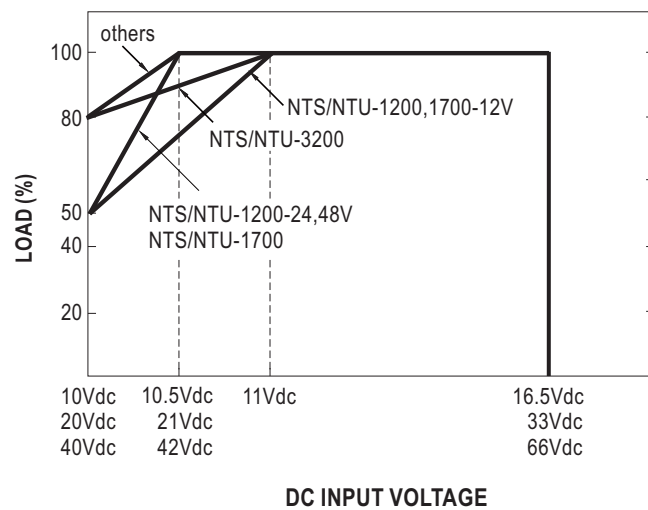
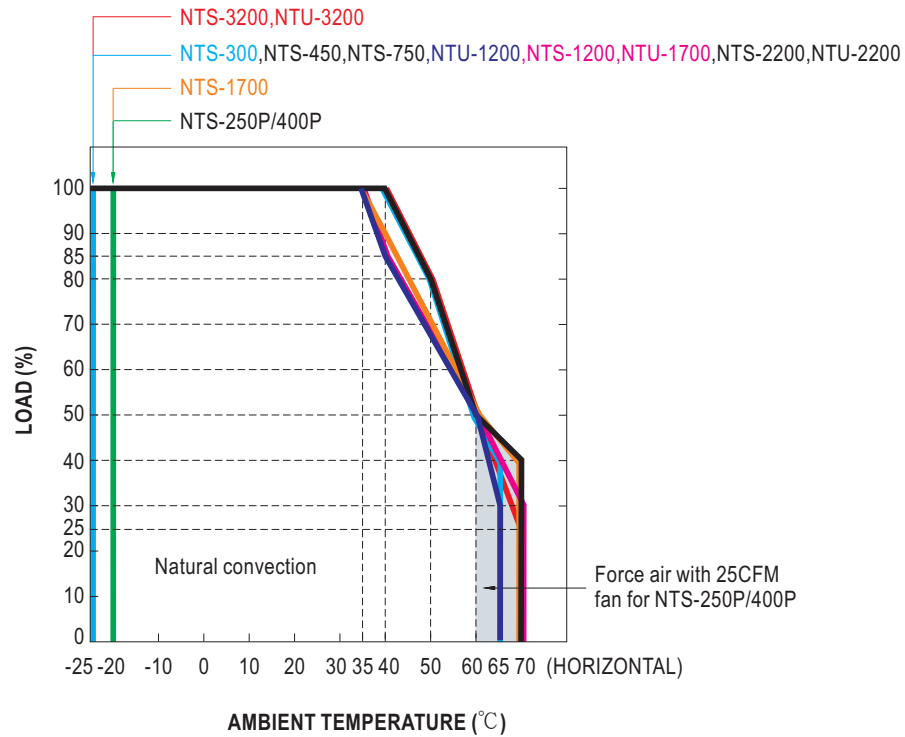

2.6 Mechanical specification

NTS-250P/400P

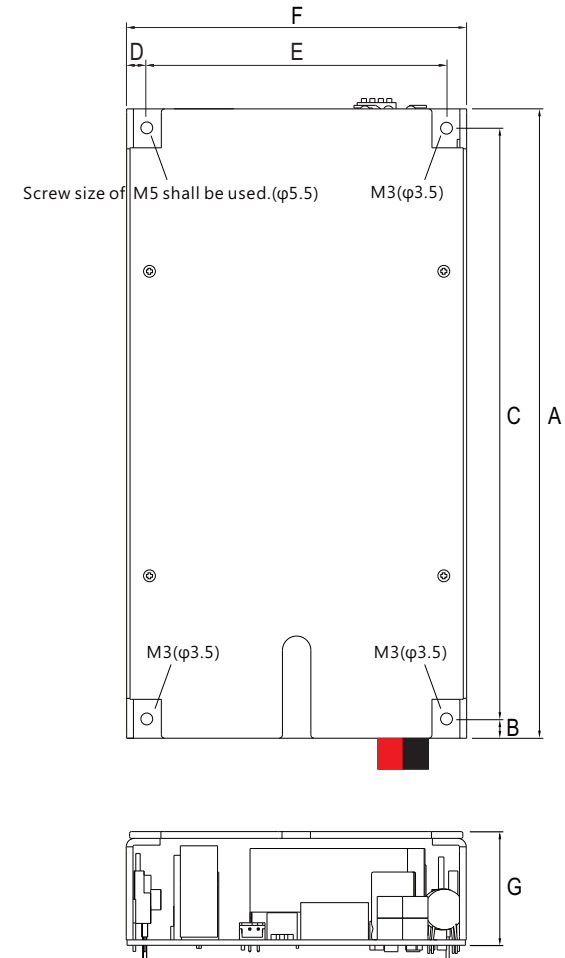

Model	A	B	C	D	E	F	G
NTS-250P	186	5.7	174.6	5.95	88.6	100.5	32
NTS-400P	186	5.7	174.6	5.95	88.6	100.5	32

Unit:mm

NTS-300/450/750

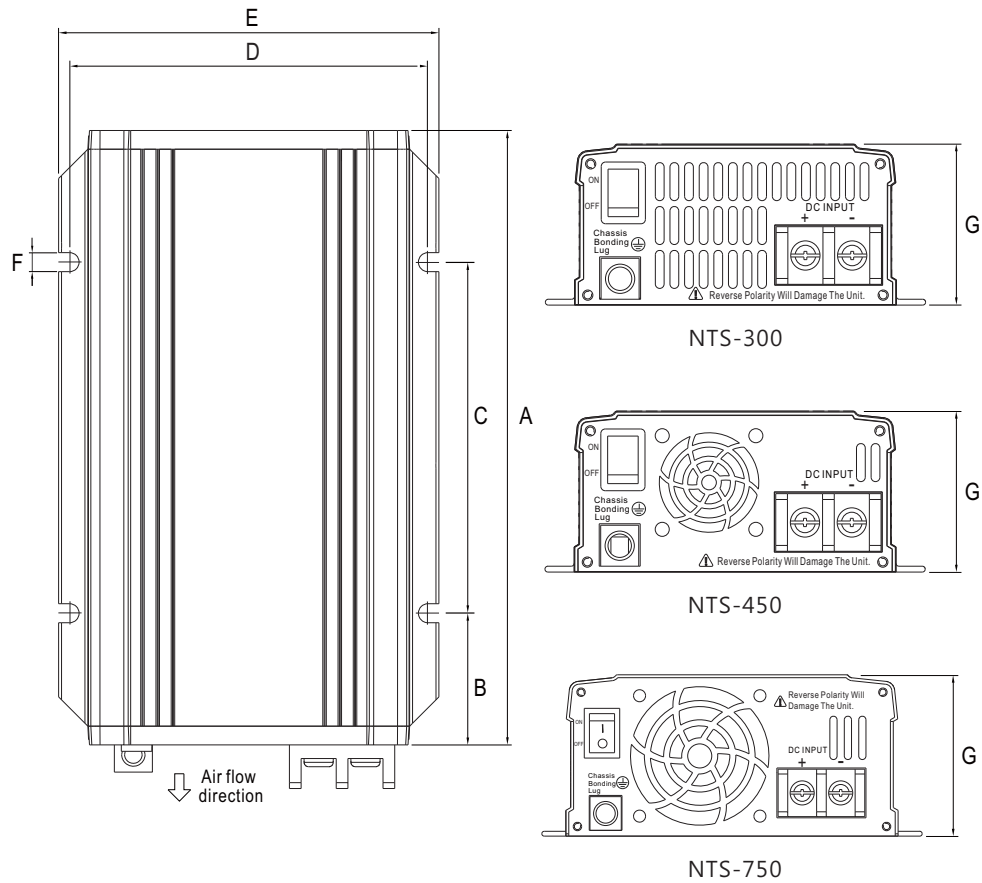

Model	A	B	C	D	E	F	G
NTS-300	210	45	120	119	130	7	55
NTS-450	210	45	120	119	130	7	55
NTS-750	270	45	180	147	158	7	67

Unit:mm

NTS/NTU-1200/1700

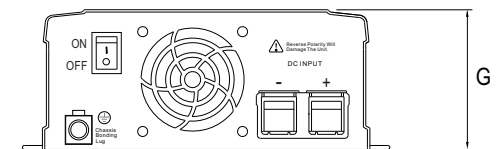
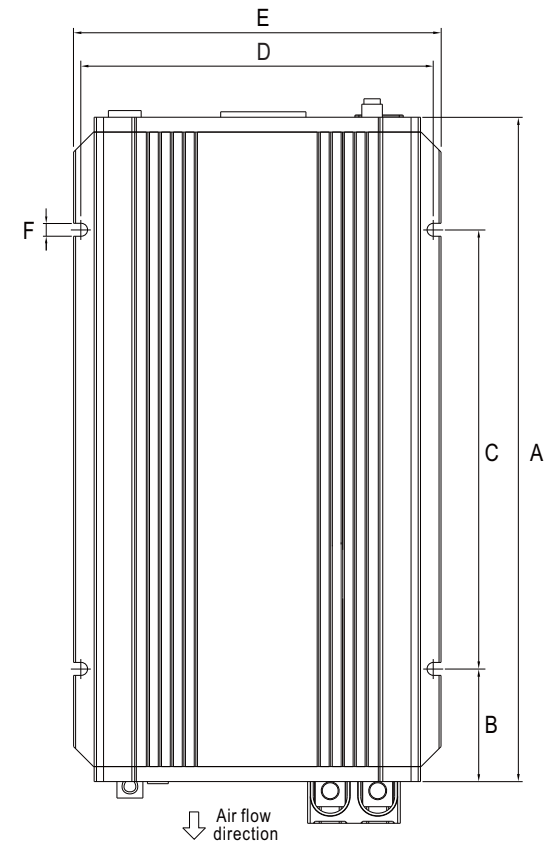

Model	A	B	C	D	E	F	G
NTS/NTU-1200	333	56.5	220	173	184	7	70
NTS/NTU-1700	400	62.5	275	173	184	7	70

Unit:mm

NTS/NTU-2200/3200

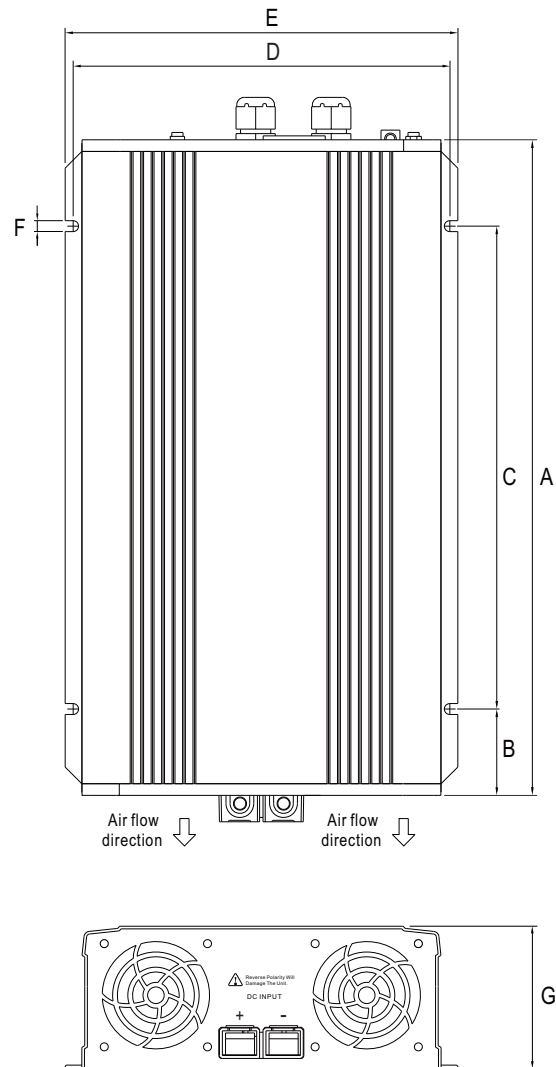

Model	A	B	C	D	E	F	G
NTS/NTU-2200	400	TBD	TBD	259	270	7.5	98
NTS/NTU-3200	440	TBD	TBD	259	270	7.5	98

Unit:mm

Accessories(Optional)

MW's Order No.	Item	Quantity
RJ11-RS232		1
Carry Handle	① Pull Handle	1
	② Foot pad	4
	③ Screw	2

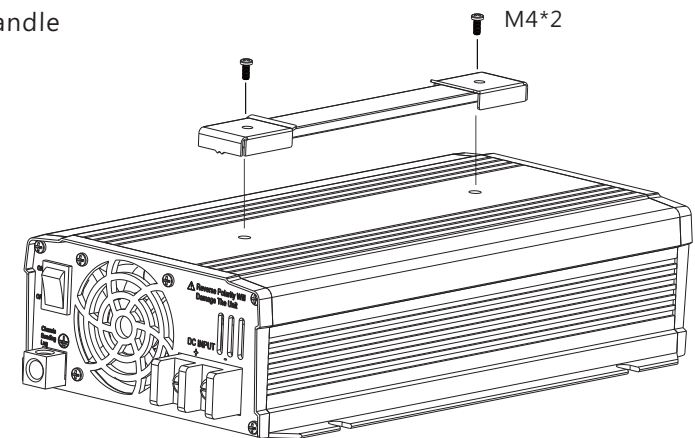

① Pull Handle

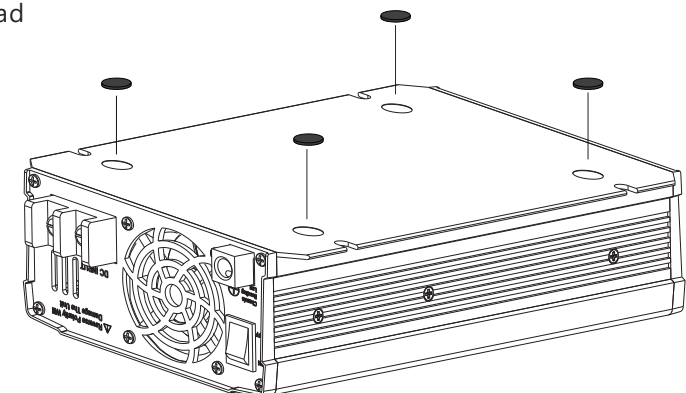

② Foot pad

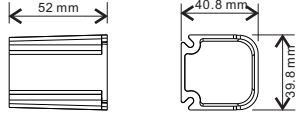

Accessories(Standard)

	Item	Quantity
①	 	1
②		1
③		4

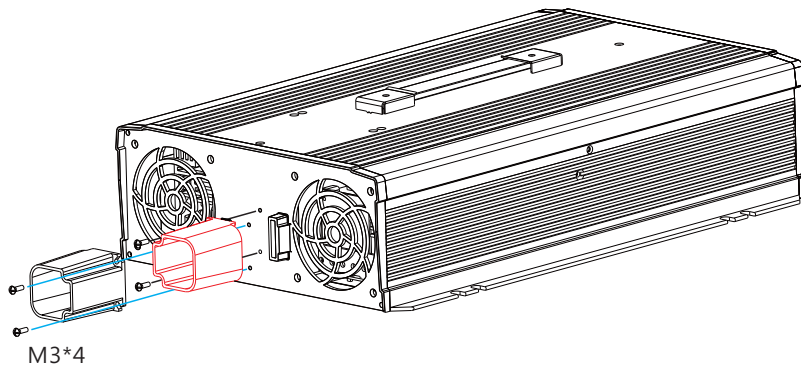

3.Installation & Wiring

3.1 Precautions

- The unit should be mounted on a flat surface or holding rack with suitable strength.
- In order to ensure the lifespan of the unit, you should refrain from operating the unit in environment of high dust or moisture.
- NTS-450~3200/NTU-1200~3200 are design with built-in DC fan. Please make sure the ventilation is not blocked. We recommend that there should be no barriers within 15cm of the ventilating slits, which is shown as follow.

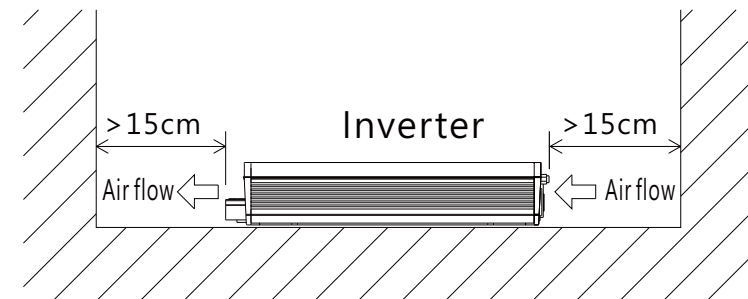

Figure 3-1 set-up recommendation

3.2 System Block Diagram

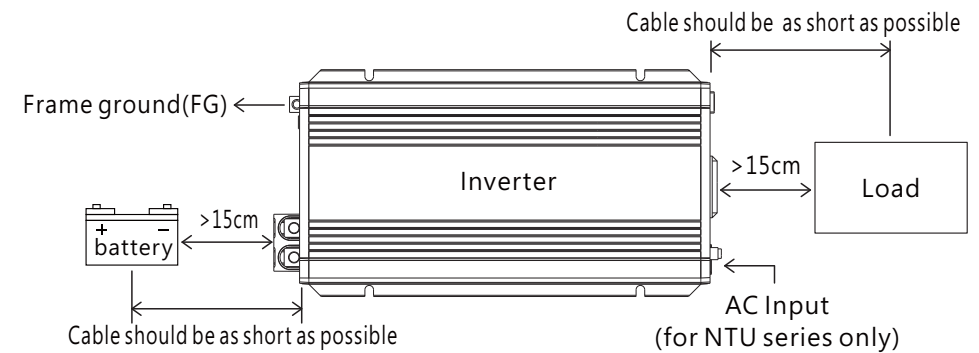
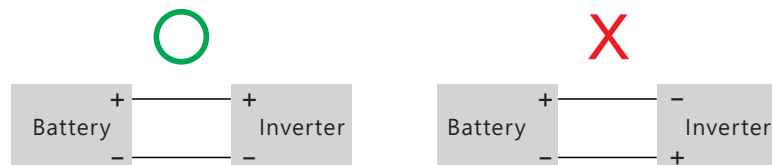

Figure 3-2 System Block Diagram

3.3 Installation procedures

- ① Please turn off the inverter first.
- ② Select proper cable for connection between battery and inverter by referring to section 3.4
- ③ Connect the positive polarity of battery to the positive terminal of inverter, and connect the negative polarity of battery to the negative terminal of inverter.



- ④ Turn the power switch to "ON" position, as soon as it shows green in status's LED, then it's ready.

3.4 Cable selection

Wire connections should be as short as possible and less than 1.5 meter is highly recommended. Make sure that suitable wires are chosen based on safety requirement and rating of current. Small cross section will result in lower efficiency, less output power and the wires may also become overheated and cause danger. Please refer to table 3-1.

Rated current(A)	Corsss section(mm ²)	AWG
10A ~ 13A	1.25	16
13A ~ 16A	1.5	14
16A ~ 25A	2.5	12
25A ~ 32A	4	10
32A ~ 40A	6	8
40A ~ 63A	10	6
63A ~ 80A	16	4
80A ~ 100A	25	2
100A ~ 125A	35	1
125A ~ 160A	50	0

Table 3-1 Cable recommendation

3.5 Battery selection

Battery types : Lead acid or lithium ion batteries

Voltage range : 10~16.5Vdc (12V), 20~33Vdc (24V), 40~66Vdc (48V)

Battery capacity : Please refer to the following table.

Model/Output	112	212	124	224	148	248
NTS-250P	85Ah or above	45Ah or above	25Ah or above			
NTS-300	100Ah or above	50Ah or above	30Ah or above			
NTS-400P	150Ah or above	70Ah or above	35Ah or above			
NTS-450	170Ah or above	85Ah or above	45Ah or above			
NTS-750	250Ah or above	130Ah or above	65Ah or above			
NTS/NTU-1200	400Ah or above	200Ah or above	100Ah or above			
NTS/NTU-1700	500Ah or above	250Ah or above	125Ah or above			
NTS/NTU-2200	735Ah or above	370Ah or above	185Ah or above			
NTS/NTU-3200	1000Ah or above	500Ah or above	250Ah or above			

3.6 GFCI socket

To meet the requirements of UL458, external GFCI socket is required for use, the following GFCI socket models are recommended(for NTU/S-2200/3200-1XXTB UL458 type):

Manufacturer	Model No.
Eaton	SGF20

4. User Interface

4.1 AC panel

- (A) **AC output socket** : Please refer to Pg. 16 for varies socket for different regions.
- (B) **No fuse breaker with reset button (only for NTU-1200/1700/2200/3200 GFCI series ; NTU-1200/1700/2200/3200 series)** :
Under "bypass mode", when the AC output is shorted or the load current exceeds the rated current of the No fuse breaker, the breaker will trip and that stops bypassing energy for the utility thus prevent possible danger. When the abnormal condition is cleared, the user can press down on the reset button to resume operation.
- (C) **Ventilation slits**: The inverter requires good ventilation for proper operation and prolonging its lifetime.
- (D) **LED indicators** : Indicate the status of inverter and the load condition.
- (E) **Communication port**: For remote monitoring purpose, the unit can be connected to a PC through this communication port by using the or a cable and monitoring software. Also for remote control purpose, the unit can be connected to the IRC module through this port.
- (F) **Power ON/OFF switch** : The inverter will turn ON if the switch is in the ON position, and vice versa.
- (G) **FG connection**
- (H) **Remote ON/OFF** : Inverter will turn on if the pins of RC connector is open. And, inverter will turn off if the pins are shorted.
- (I) **AC bypass socket** : When AC mains is available, by connecting the AC mains to the AC socket, it will enable AC bypass function, which the Energy will provide to load from AC mains directly. Please use UL Listed power supply cord, 14AWG/3C, Type SJ/SJT/SJO/SPT-3, terminates in a grounding type 3 prong molded-on attachment plug (NEMA 5-20P). Maximum 0.9 m long.

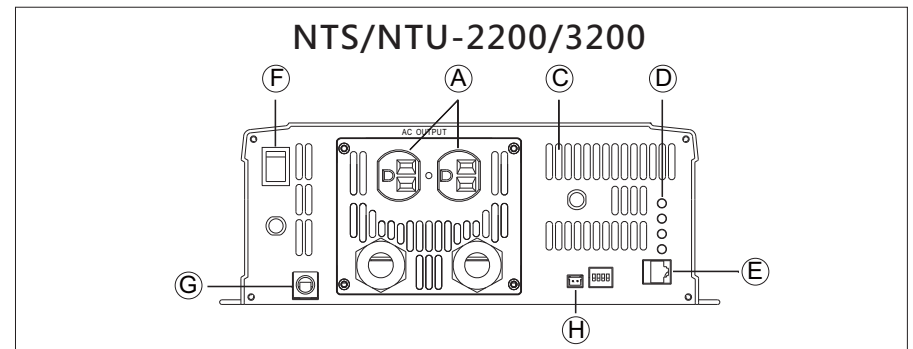
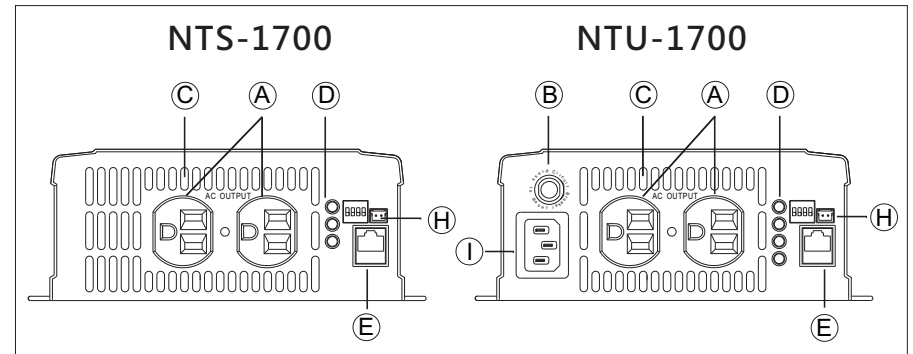
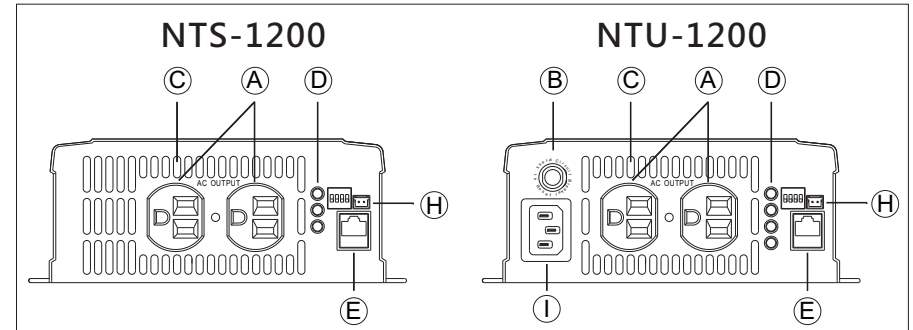
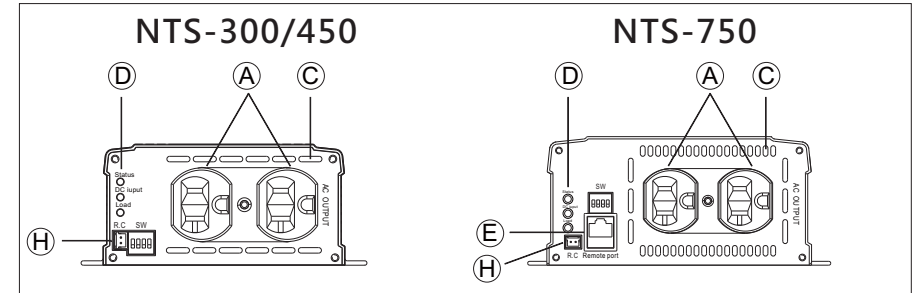

4.2 DC input panel

- Ⓐ POWER ON/OFF switch: The inverter will turn ON if the switch is in the ON position, and vice versa.
- Ⓑ Input terminals (+), (-)
- Ⓒ Frame ground (FG)
- Ⓓ Ventilation slits: The inverter requires suitable ventilation to work properly. Please make sure there is good ventilation and the lifespan of the inverter can be preserved.

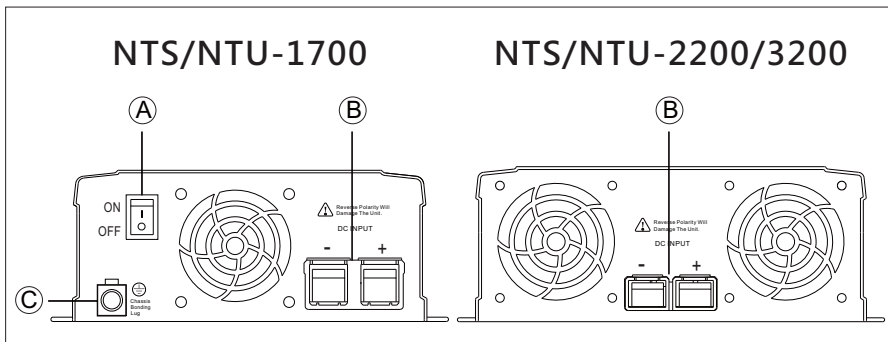
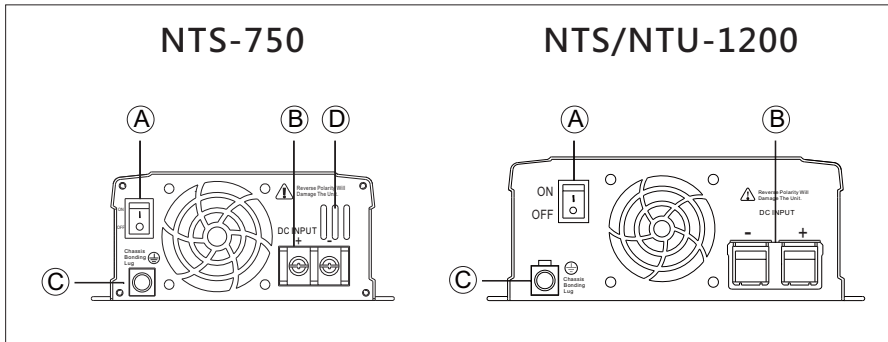
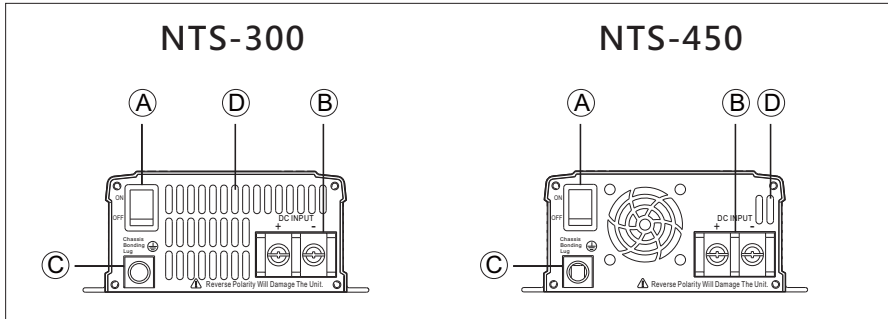

4.3 LED Indicator

Status indicator :

The LED is used to indicate the status of inverter, including inverter OK, remote on/off and power saving mode.

Status	Green	Orange	Red
	<ul style="list-style-type: none"> ☀ System check ● Inverter OK 	<ul style="list-style-type: none"> ● Remote off ☀ Saving mode 	<ul style="list-style-type: none"> ● Abnormal Status (See below table)

DC Input Indicator :

It is used to show the input status of inverter.

Green light :

When input voltage is greater than 12.5V(12V)/25V(24V) 50V(48V).

Orange light :

When input voltage is within 11V~12.5V(12V)/22V~25V(24V)/44V~50V(48V).

Red light :

When input voltage is lower than 11V(12V)/22V(24V)/44V(48V) or over it's specification. It flashes and warning sound will be activated.

DC Input	Green	Orange	Red
	<ul style="list-style-type: none"> ● 12.5~15.5Vdc ● 25~31Vdc ● 50~62Vdc 	<ul style="list-style-type: none"> ● 11~12.5Vdc ● 22~25Vdc ● 44~50Vdc 	<ul style="list-style-type: none"> ● <11Vdc or >15.5Vdc ● <22Vdc or >31Vdc ● <44Vdc or >62Vdc

Load Condition Indicator :

It represents the magnitude of output loads

Green light : When load is lesser than 40%.

Orange light : When load is between 40%~80%.

Red light : When load is greater than 80%.

Load	Input mode	Green	Orange	Red
	Mains priority	● <40% load	● 40~80% load	● >80% load
Battery Priority	☀ <40% load	☀ 40~80% load	☀ >80% load	

AC Input Indicator :

Represents the magnitude of AC main.

Green light :

When AC mains is connected and the voltage is present normally.

Flash in green light :

When the mains is connected but the voltage exceeds $\pm 10\%$ of the rated voltage, the green light will start flashing for warning.

Light off :

when the mains is disconnected or not connected, LED will be in off.

AC Input	Green	
	●	Utility OK
☼	Utility error	
○	Utility disconnect	

- Light
- ☼ Flash
- Light off

5.Explanation of Operation

5.1 Procedure of setting Operating Mode, Output Voltage, Frequency, and Saving Mode

5.1.1 Output Voltage and Frequency Setting

Factory settings are either 110Vac/60Hz or 230Vac/50Hz, users are able to adjust the voltage and frequency, through the DIP switch of position 1,2,3,4 on the AC panel.

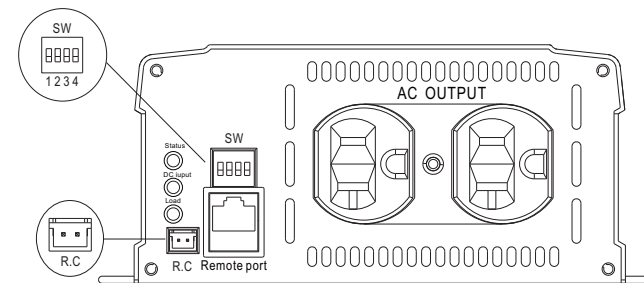

Type-US

AC Output Voltage、 Frequency、 Power Saving Mode、 Selectable by DIP SW			
SW1	SW2	SW3	SW4
OFF	OFF : 100Vac or 200Vac	ON : 50Hz	ON : Power saving mode
OFF	ON : 110Vac or 220Vac		
ON	OFF : 115Vac or 230Vac	OFF: 60Hz	OFF: Non-power saving mode
ON	ON : 120Vac or 240Vac		

5.1.2 Power Saving Mode setting

When the inverter is in no load status, in order to reduce battery energy consumption by inveter accidentally, Position 4 of DIP S.W. on the panel of inverter, can be adjusted to the "ON" position. When this mode is activated, if the load is less than 10W, the inverter will turn off the output and enter the power saving mode after 3 second. In the power saving mode, the inverter MCU will periodically detect the output load status. When a load greater than 25W is connected, the inverter will switch back to normal mode and start output again. (Non-power saving mode is used as factory setting).

NOTE: Fan stops at power saving mode.

5.1.3 Remote ON/OFF

R.C Switch	
Open	Normal work
Short	Remote off

5.1.4 Battery /Mains Priority Setting

NTS-1700 is factory set to mains priority, if you want to set battery priority, you need to switch the DIP of battery preference in the remote off state, the procedure is as follows:

- ① When the power is not being sent, turn the 2 and 3 DIP switches of the selected DIP_SW to the "OFF" state
- ② BAT power supply in remote off mode
- ③ Within 15 seconds of power transmission, switch 2 and 3 of the DIP_SW to full "ON", and then switch back to full "OFF"
- ④ All LEDs (except AC input) flash green 3 times, indicating that the setting is successful
- ⑤ Turn off NTU and turn on the external Remote switch
- ⑥ Turn on NTU to load battery priority mode

To turn off the battery priority setting, follow these steps:

- ① When the power is not being sent, turn the 2 and 3 DIP switches of the selected DIP_SW to the "ON" state
- ② BAT power supply in remote off mode
- ③ Within 15 seconds of power transmission, switch the 2 and 3 switches of the DIP_SW to full "OFF", and then switch back to full "ON"
- ④ All LEDs (except AC input) flash green 3 times, indicating that the setting is successful
- ⑤ Turn off NTU and turn on the external Remote switch
- ⑥ Turn on NTU to load the AC priority function

5.2 Function Difference

Funtion/model	NTS-250P/400P	NTS-300/450	NTS-750/1200/1700/2200/3200	NTU-1200/1700/2200/3200
Support IRC	X	X	●	●
Support RS-232	X	X	●	●
Support UART	●	X	X	X
UPS Function	X	X	X	●
Battery priority	X	X	X	●

- Standard

NOTE: Built-in thermal controlled DC fan. Fan stops at low internal temperature.

5.3 IRC1/IRC2/IRC3 Remote Control Unit

- IRC1/IRC2/IRC3 is the monitoring and control unit used for the inverter series.
- IRC1/IRC2/IRC3 can decode the RS-232 signals sent by the inverter series and display through digital meters.

Note: Part of the control signals will not function properly due to different compliance of each model.

MODEL		IRC1	IRC2	IRC3
OUTPUT	DIGITAL METER	----	Display the battery level, output load level, and operating status of inverter unit	
	CONTROL OUTPUT	Remote ON/OFF for inverter unit		
	LED INDICATOR	Remote turn ON(Green); Remote turn Off(Orange); Abnormal (Red); Saving mode (Orange flash)		
FUNCTION	REMOTE ON/OFF CONTROL	The controlled inverter unit can be turned ON/OFF on the remote control panel for IRC1 / IRC2 / IRC3		
	POWER SAVING CONTROL	Power saving enable / disable activation		
	SUITABLE SERIES	TS-700 / 1000 / 1500 / 3000 TN-1500 / 3000 NTS-750 / 1200 / 1700 / 2200 / 3200 NTU-1200 / 1700 / 2200 / 3200	TS-700 / 1000 / 1500 / 3000 NTS-750 / 1200 / 1700 / 2200 / 3200 NTU-1200 / 1700 / 2200 / 3200	TN-1500 / 3000 NTS-750 / 1200 / 1700 / 2200 / 3200 NTU-1200 / 1700 / 2200 / 3200
ENVIRONMENT	WORKING TEMP.	-20 ~ +50℃		
	WORKING HUMIDITY	20 ~ 90% RH non-condensing		
	STORAGE TEMP., HUMIDITY	-40 ~ +85℃, 10 ~ 95% RH non-condensing		
	VIBRATION	10 ~ 500Hz, 2G 10min./1cycle, 60min. each along X, Y, Z axes		
EMC	EMC EMISSION	Compliance to EN55032 class A, EN61000-3-2,3, FCC PART 15 class A		
	EMC IMMUNITY	Compliance to EN61000-4-2,3,4,6,8		
OTHER	DIMENSION (L*W*H) (Unit:mm)	186*100.5*32mm (L*W*H)		
	PACKING	0.75Kg; 18pcs/ 14.5Kg/ 0.97CUFT		
NOTE	1. The remote control can not re-power on for inverter at abnormal status. 2. The ambient temperature derating of 3.5℃/1000m with fanless models and of 5℃/1000m with fan models for operating altitude higher than 2000m(6500ft). ※: Product Liability Disclaimer : For detailed information, please refer to https://www.meanwell.com/serviceDisclaimer.aspx			

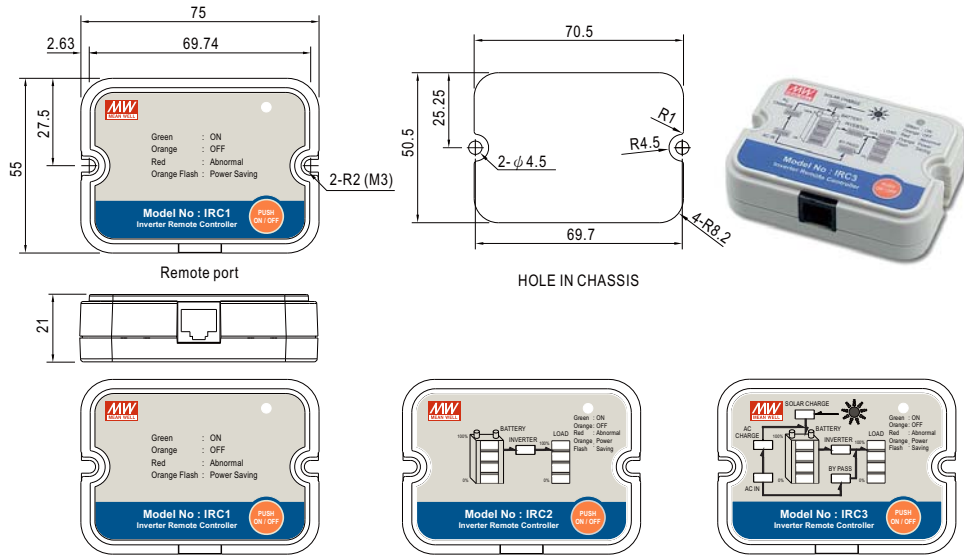

5.4 RS-232/UART Protocol

RS-232/UART communication can be used between NTS/NTU series products and external controller (Controller) or PC software. The internal data of a single NTS/NTU unit can be read through RS-232 or UART, but multiple units on a bus is not allowed.

The RS-232/UART parameters of NTS/NTU series are defined as follows:

Parameter	Setting
Baud Rate	9600
Data Bits	8
Stop Bit	1
Parity	None
Flow Control	None

Definition of MEAN WELL RS-232 protocol:

Command Code	Type	Command name
Q	R	Status Inquiry
C	W	Remote Control
V	R/W	Write voltage/Frequency Write: Need to enable with "pU" command first
pU	W	Enable/disable setting mode (for command "V")
I	R	INVERTER Information
W	W	Write Information into INVERTER EEPROM
U	R/W	Write UVP Transfer voltage · OVP Transfer voltage

Communication sequence

Min. request period (Controller/PC to NTS/NTU): 500mSec ◦

Max. response time (NTU/NTS to Controller/PC): 15mSec ◦

Min. packet margin time (Controller/PC to NTS/NTU): 10mSec ◦

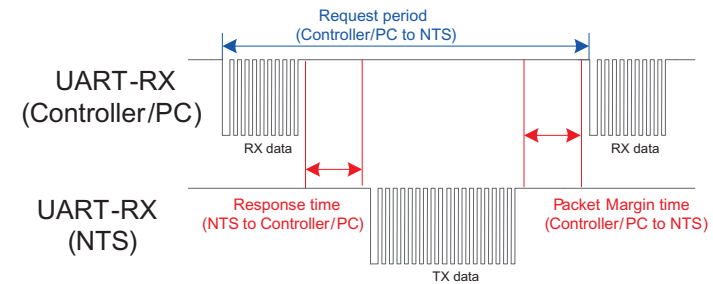

The write format and reply format of communication protocol

NTS/NTU communications are transmitted by using ASCALL codes. The end character of communication command is CR(0x0D), also CRLF (0x0D 0x0A) is the most common end character. Therefore, when decoding data, pay attention to whether LF (0x0A) is included and clear it to avoid data confusion. To improve transmission quality, some commands contain Checksum.

The Checksum is calculated as follows:

- ① Reset the Checksum in the Checksum data to zero.
- ② Add all the data before Checksum data. Including V or I commands.
- ③ If the total data is less than 2 bytes, add 0 to make up 2 bytes.

For example, the V command sets the inverter output to 110VAC/50Hz. The format of the V instruction is as follows :

0	1-3	4	5-7	8-9	10
V(0x56)	Voltage	SP(0x20)	Frequency	Checksum	CR(0x0D)

Fill in the instructions in the above format and the instruction data except checksum is as follows:

V(0x56)	1(0x31)	1(0x31)	0(0x30)	SP(0x20)	0(0x30)	5(0x35)	0(0x30)	checksum	CR(0x0D)
---------	---------	---------	---------	----------	---------	---------	---------	----------	----------

- ① Reset the Checksum data to zero
- ② The checksum data is the sum of all written data
Sum = 56 + 31 + 31 + 30 + 20 + 30 + 35 + 30 = 19D
- ③ Checksum = 01 9D

The format of the V command is as follows:

V(0x56)	1(0x31)	1(0x31)	0(0x30)	SP(0x20)	0(0x30)	5(0x35)	0(0x30)	0x019D	CR(0x0D)
---------	---------	---------	---------	----------	---------	---------	---------	--------	----------

Note: For details about the format of the V command, see the following write / read format and definition description.

The Q command: Used to confirm the inverter status, the parameters can be output voltage, output load percent (Digital), battery voltage, battery capacity, heat sink temperature, utility power voltage, output power frequency, DC bus, output load percent (Analog) and etc.

Write format:

0	1
Q(0x51)	CR(0x0D)

Reply format:

0	1~3	4	5~7	8	9~12	13	14~16
((0x28)	O/P Voltage	SP(0x20)	O/P load (Digital)	SP(0x20)	Battery voltage	SP(0x20)	Battery capacity
17	18~21	22	23~25	26	17~30	31	32~34
SP(0x20)	Heat Sink Temperature	SP(0x20)	Utility Power Volt.	SP(0x20)	Output Power Freq.	SP(0x20)	DC BUS Voltage
35	36~38	39	40	41	42	43	44
SP(0x20)	O/P Load (Analog)	SP(0x20)	b0	b1	b2	b3	b4
45	46	47	48	49	50	51	52
b5	b6	b7	b8	b9	b10	b11	b12
53	54	55	56	57	58	59	60
b13	b14	b15	b16	b17	b18)(0x29)	CR(0x0D)

Definition of command(Q)

49 byte data flow of command Q		(VVV QQQ SS.S BBB TT.T MMM RR.R DDD PPP b0b1b2b3b4b5b6b7b8b9b10b11b12b13b14b15b16b17b18)				
Data byte	Funtion name	Description	R/W	Range	Data type	Uint
VVV,3	O/P Voltage	O/P Voltage	R	0~250Vac	U1	ASCII
QQQ,3	O/P load percent (Digital)	O/P load percent (Digital)	R	0% =000 0 < ~ ≤30% =025 31 < ~ ≤50% =050 51 < ~ ≤75% =075 76 < ~ % =100	U1	ASCII
SS.S,4	Battery voltage	Battery voltage	R	12: 0~17.0Vdc 24: 0~34.0Vdc 48: 0~68.0Vdc	U1	ASCII
BBB,3	Battery capacity	Battery capacity	R	0 ≤ ~ < 25% =025 26 < ~ ≤50% =050 51 < ~ ≤75% =075 76 < ~ ≤100% =100	U1	ASCII
TT.T,4	Heat Sink Temperature	Heat Sink Temperature	R	0~99.9°C	U1	ASCII
MMM,3	Utility Power Voltage	Utility Power Voltage	R	0~250Vac	U1	ASCII
RR.R,4	Output Power Frequency	Output Power Frequency	R	40.0~70.0 Hz	U1	ASCII
DDD,3	DC BUS Voltage	DC BUS Voltage	R	0V	U1	ASCII
PPP,3	O/P load Percent (Analog)	O/P load Percent (Analog)	R	0~100%	U1	ASCII
b0,1	INVERTER Mode	INVERTER Mode	R	1: INVERTER Mode	U1	ASCII
b1,1	Bypass Mode	Bypass Mode	R	1: Bypass Mode	U1	ASCII
b2,1	Utility Power supply	Utility Power supply	R	1: Utility Power	U1	ASCII

Data byte	Funtion name	Description	R/W	Range	Data type	Uint
b3,1	Utility Charger Enable	Utility Charger Enable	R	1: Enable	U1	ASCII
b4,1	Solar Charger Enable	Solar Charger Enable	R	1: Enable	U1	ASCII
b5,1	Saving Mode Occurred	Saving Mode Occurred	R	1: Saving Mode	U1	ASCII
b6,1	Battery Exhausted Mode	Battery Exhausted Mode	R	1: Battery low	U1	ASCII
b7,1	Shutdown Mode (Battery used up)	Shutdown Mode (Battery used up)	R	Shutdown Mode (Battery used up)	U1	ASCII
b8,1	Battery OVP	Battery OVP	R	1: Battery OVP	U1	ASCII
b9,1	Remote Shutdown	Remote Shutdown	R	1: Remote Shutdown	U1	ASCII
b10,1	OLP 100 ~ 115 %	OLP 100 ~ 115 %	R	1: Occurred OLP 100%~	U1	ASCII
b11,1	OLP 115 ~ 150 %	OLP 115 ~ 150 %	R	1: Occurred OLP 115%~	U1	ASCII
b12,1	OLP 150% ~	OLP 150% ~	R	1: Occurred OLP 150%~	U1	ASCII
b13,1	OTP	OTP	R	1: Inverter OTP 2: Fan lock protection	U1	ASCII
b14,1	INV UVP	INV UVP	R	1: INV UVP protection	U1	ASCII
b15,1	INV OVP	INV OVP	R	1: INV OVP protection	U1	ASCII
b16,1	INV Fault	INV Fault	R	1: INV Fault	U1	ASCII

Data byte	Funtion name	Description	R/W	Range	Data type	Uint
b17,1	EEPROM error code	EEPROM error code	R	1: EEPROM error	U1	ASCII
b18,1	System Shutdown	System Shutdown	R	1: Shutdown	U1	ASCII

The C command: Used to remote control inverter.

Write format :

Remote OFF

0	1	2	3	4	5	6	6	8
C(0x43)	1(31)	0(30)	0(30)	0(30)	0(30)	0(30)	0(30)	0(30)
9	10	11	12	13	14	15	16	
0(30)	0(30)	0(30)	0(30)	0(30)	0(30)	0(30)	CR(0x0D)	

Remote ON

0	1	2	3	4	5	6	6	8
C(0x43)	0(30)	1(31)	0(30)	0(30)	0(30)	0(30)	0(30)	0(30)
9	10	11	12	13	14	15	16	
0(30)	0(30)	0(30)	0(30)	0(30)	0(30)	0(30)	CR(0x0D)	

Reply format :

0
C(0x43)

Definition of command(C)

15 byte data flow of command C		(Cb0b1b2b3b4b5b6b7b8b9b10b11b12b13b14)				
Data byte	Funtion name	Description	R/W	Range	Data type	Uint
b0,1	Shut down	Shut down	W	1: Remote Shutdown	U1	ASCII
b1,1	Turn on INVERTER	Turn on INVERTER	W	1: Remote On INV	U1	ASCII
b2,1	Preserved	Preserved		Fixed" 0x30"	U1	ASCII
b3,1	Preserved	Preserved		Fixed" 0x30"	U1	ASCII
b4,1	Preserved	Preserved		Fixed" 0x30"	U1	ASCII
b5,1	Preserved	Preserved		Fixed" 0x30"	U1	ASCII
b6,1	Preserved	Preserved		Fixed" 0x30"	U1	ASCII

Data byte	Funtion name	Description	R/W	Range	Data type	Uint
b7,1	Preserved	Preserved		Fixed" 0x30"	U1	ASCII
b8,1	Preserved	Preserved		Fixed" 0x30"	U1	ASCII
b9,1	Preserved	Preserved		Fixed" 0x30"	U1	ASCII
b10,1	Preserved	Preserved		Fixed" 0x30"	U1	ASCII
b11,1	Preserved	Preserved		Fixed" 0x30"	U1	ASCII
b12,1	Preserved	Preserved		Fixed" 0x30"	U1	ASCII
b13,1	Preserved	Preserved		Fixed" 0x30"	U1	ASCII
b14,1	Preserved	Preserved		Fixed" 0x30"	U1	ASCII

The V command : Used to change output voltage and frequency.You need to send the "pU" command to unlock it before executing the V command.

Write format :

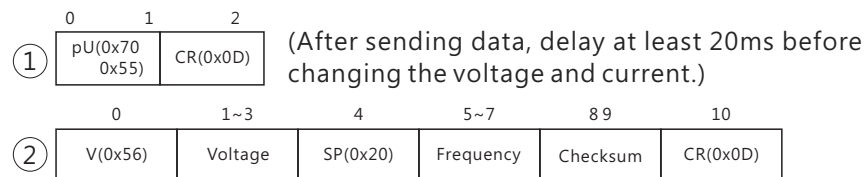

Reply format :

If the transmission parameters are correct, the inverter replies:

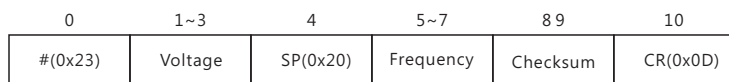

If the transmission parameters are not correct, the inverter replies as follows, please confirm and retry.

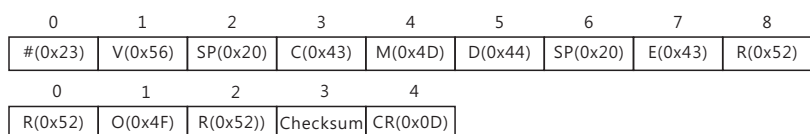

Definition of command(V)

8 byte data flow of command V		(VWWW FFF)				
Data byte	Funtion name	Description	R/W	Range	Data type	Uint
WWW,3	Voltage setting	To set any AC Voltage within the range	W/R	110 Series 100~120 : 100~120Vac	U1	ASCII
				220 Series 200~240 : 200~240Vac		
				000: Restore factory voltage setting (DIP switch setting mode)(Note)		
FFF,3	Frequency setting	Frequency setting	W/R	050 : 50Hz 060 : 60Hz 000 : Restore factory frequency setting (DIP switch setting mode)(Note)	U1	ASCII
2	Checksum	Checksum				

Note: After setting voltage or frequency by "V" command, disconnect communication,the product can still maintain the set value.If you want to switch back to DIP switch settings.Please send 0(0x30)0(0x30)0(0x30) for voltage and frequency, and the new setting will take effect after restart.

The I command : Used to read inverter information. The parameters contain the inverter output voltage, frequency, model code, equalization voltage, floating voltage, alarm voltage, shutdown voltage and etc.

Write format:

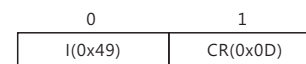

Reply format:

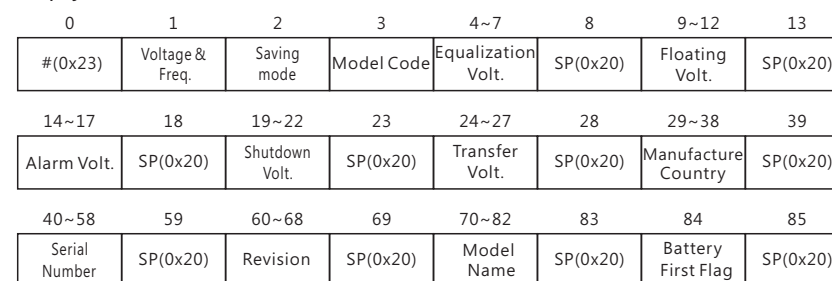

86~95	96 97	98
Date	Checksum	CR(0x0D)

The W command: Used to modify inverter specifications. Such as alarm voltage, shutdown voltage, serie number, model name · Battery priority mode, mains priority mode, etc.

Write format:

0	1	2	3	4~7	8	9~12	13
W(0x57)	Voltage & Freq.	Saving mode	Model Code	Equalization Volt.	SP(0x20)	Floating Volt.	SP(0x20)
14~17	18	19~22	23	24~27	28	29~38	39
Alarm Volt.	SP(0x20)	Shutdown Volt.	SP(0x20)	Transfer Volt.	SP(0x20)	Manufacture Country	SP(0x20)
40~58	59	60~68	69	70~82	83	84	85
Serial Number	SP(0x20)	Revision	SP(0x20)	Model Name	SP(0x20)	Battery First Flag	SP(0x20)
86~95	96 97	98					
Date	Checksum	CR(0x0D)					

Reply format:

If the transmission parameters are correct, the inverter replies:

0	1	2	3	4~7	8	9~12	13
#(0x23)	Voltage & Freq.	Saving mode	Model Code	Equalization Volt.	SP(0x20)	Floating Volt.	SP(0x20)
14~17	18	19~22	23	24~27	28	29~38	39
Alarm Volt.	SP(0x20)	Shutdown Volt.	SP(0x20)	Transfer Volt.	SP(0x20)	Manufacture Country	SP(0x20)
40~58	59	60~68	69	70~82	83	84	85
Serial Number	SP(0x20)	Revision	SP(0x20)	Model Name	SP(0x20)	Battery First Flag	SP(0x20)
86~95	96 97	98					
Date	Checksum	CR(0x0D)					

If the transmission parameters are not correct, the inverter replies as follows, Please confirm and retry.

0	1	2	3	4	5	6	7	8
#(0x23)	W(0x57)	SP(0x20)	C(0x43)	M(0x4D)	D(0x44)	SP(0x20)	E(0x43)	R(0x52)
0	1	2	3	4				
R(0x52)	O(0x4F)	R(0x52)	Checksum	CR(0x0D)				

Definition of command(I · W)

87 byte data flow of command I · W		(I/WVDMEE.E FF.F AA.A SS.S TT.T MEANWELL LOC-XXXXXXXXXXXXXXXXX vv.v XXXXXXXXXXXXX B MM/DD/YYYY)				
Data byte	Funtion name	Description	R/W	Range	Data type	Uint
V,1	Voltage & Freq. setting	Voltage & Freq. setting	R	100V(200V)/50Hz=00 110V(220V)/50Hz=01 115V(230V)/50Hz=02 120V(240V)/50Hz=03 100V(200V)/60Hz=04 110V(220V)/60Hz=05 115V(230V)/60Hz=06 120V(240V)/60Hz=07 <i>(Defined by DIP SW)(Note1)</i>	U1	Binary
D,1	Saving mode	Saving mode	R	Disable=00 Enable=01 <i>(Defined by DIP SW)(Note1)</i>	U1	Binary
M,1	Model Code	Model Code	R	112=00 124=01 148=02 212=03 224=04 248=05 <i>(Defined by DIP SW)(Note1)</i>	U1	Binary
EE.E,4	Equalization Volt.	Equalization Volt.	W/R	12: 9.0~15.0Vdc 24: 18.0~30.0Vdc 48: 36.0~60.0Vdc <i>(Unsupported)(Note2)</i>	U1	ASCII
FF.F,4	Floating Volt.	Floating Volt.	W/R	12: 9.0~15.0Vdc 24: 18.0~30.0Vdc 48: 36.0~60.0Vdc <i>(Unsupported)(Note2)</i>	U1	ASCII
AA.A,4	Alarm Volt.	Alarm Volt.	W/R	12: 9.9~12.5Vdc 24: 19.8~25.0Vdc 48: 39.6~50.0Vdc <i>(Note3)</i>	U1	ASCII

Data byte	Funtion name	Description	R/W	Range	Data type	Uint
SS.S,4	Shutdown Volt.	Shutdown Volt.	W/R	12: 9.7~12.0Vdc 24: 19.4~24.0Vdc 48: 38.8~48.0Vdc (Note 3)	U1	ASCII
TT.T,4	Transfer Volt.	Transfer Volt.	W/R	12: 9.0~15.0Vdc 24: 18.0~30.0Vdc 48: 36.0~60.0Vdc (Unsupported)(Note2)	U1	ASCII
10	Manufacture Country	Manufacture Country	W/R	MEANWELL (Note4)	U1	ASCII
19	Serial Number	Serial Number	W/R	LOC-xxxxxxxxxxxxxxxx (x: 0~9)	U1	ASCII
9	Revision	Revision	R	REV:vv.v (Defined by Firmware, not changeable)	U1	ASCII
13	Model Name	Model Name	W/R	Define by each model (max of 14 digits)	U1	ASCII
B,1	Battery First Flag	Battery First Flag	W/R	0 = Disable 1 = Enable	U1	ASCII
10	Date	Date	W/R	Date : MM/DD/YYYY	U1	ASCII
2	Checksum	Checksum				

- ① The read value can be any arbitrary code, the BYTE length must be met when writing data, and the value can be arbitrary.
- ② If the related parameters are unsupported · please set the maximum voltage when writing :
12V: 15.0V (0x31 0x35 0x2E 0x30)
24V: 30.0V (0x33 0x30 0x2E 0x30)
48V: 60.0V (0x36 0x30 0x2E 0x30)
- ③ The battery voltage setting must meet the following conditions:12.5V \geq Alarm_Volt.>Shutdown_Volt. \geq 9.7V. And Alarm_Volt. - Shutdown_Volt. \geq 0.2V. If the above conditions are not met, the setting is invalid.
- ④ If the data cannot fill the number of bytes set by the instruction ,please write in blank code(0x20) after the write data. For example, the manufacturer "MEANWELL" has 8 bits, and 2 bits need to be added. The ASCII code is:

M(0x4D)	E(0x45)	A(0x41)	N(0x4E)	W(0x57)	E(0x45)	L(0x4C)	0(0x20)	0(0x20)
---------	---------	---------	---------	---------	---------	---------	---------	---------

U Command: Used for battery undervoltage conversion voltage setting and battery overvoltage conversion voltage setting in battery priority mode, only applicable to NTU models.

Write format :

0	1 ~ 4	5	6 ~ 9	10	11~14	15	16~19
#(0x55)	UVP Transfer Voltage	SP(0x20)	OVP Transfer voltage	SP(0x20)	V1	SP(0x20)	V2
20	21~24	25	26~29	30 31	32		
SP(0x20)	V3	SP(0x20)	V4	Checksum	CR(0x0D)		

Note: V1, V2, V3, and V4 are reserved parameters, all of which are 4 bytes, and the content is a fixed value: 0x30 0x30 0x2E 0x30.

Reply format :

If the Controller/PC transmits the setting parameters correctly, NTU replies:

0	1 ~ 4	5	6 ~ 9	10	11~14	15	16~19
#(0x23)	UVP Transfer Voltage	SP(0x20)	OVP Transfer voltage	SP(0x20)	V1	SP(0x20)	V2
20	21~24	25	26~29	30 31	32		
SP(0x20)	V3	SP(0x20)	V4	Checksum	CR(0x0D)		

If the Controller/PC transmission setting parameters are incorrect, NTU will reply: Please confirm and retransmit.

0	1	2	3	4	5	6	7	8
#(0x23)	U(0x55)	SP(0x20)	C(0x43)	M(0x4D)	D(0x44)	SP(0x20)	E(0x43)	R(0x52)
9	10	11	12 ~13	14				
R(0x52)	O(0x4F)	R(0x52)	Checksum	CR(0x0D)				

Definition of command (U) :

Data byte	Funtion name	Description	R/W	Range	Data	Uint
4	UVP Transfer Voltage	Battery Priority Mode: Battery undervoltage conversion voltage setting (Note 1)	W/R	12:9.9~12.5Vdc 24:19.8~25.0Vdc 48:39.6~50.0Vdc Default: 12: 11Vdc 24: 22Vdc 48: 44Vdc (Note 2)	U1	ASCII
4	OVP Transfer Voltage	Battery Priority Mode: Battery overvoltage conversion voltage setting (Note 1)	W/R	12:10.5~15.5Vdc 24:21.0~32.0Vdc 48:42.0~64.0Vdc Default: 12: 14.4Vdc 24: 28.8Vdc 48: 57.6Vdc (Note 2)	U1	ASCII
4	V1	Preserved	W/R	Fixed 0x30 0x30 0x2E 0x30	U1	ASCII
4	V2	Preserved	W/R	Fixed 0x30 0x30 0x2E 0x30	U1	ASCII
4	V3	Preserved	W/R	Fixed 0x30 0x30 0x2E 0x30	U1	ASCII
4	V4	Preserved	W/R	Fixed 0x30 0x30 0x2E 0x30	U1	ASCII
4	Checksum	The sum of the data contents (Not included Checksum)			U1	ASCII

Note:

1 In battery priority mode, the premise of triggering OVP is to trigger UVP, and after the battery voltage reaches the UVP conversion point, it switches to AC to power supply and charges the battery. After the battery voltage reaches the OVP conversion point, it switches to DC power supply and is discharged by the battery. (In the battery priority mode, the battery voltage is lower than the set battery undervoltage conversion voltage, and the power supply is switched to AC. Wait until the battery voltage reaches the set battery overvoltage conversion voltage, and then switch back to DC mode.)

2 The battery voltage setting must meet the following conditions (for example, the 12V model) : $9.9 \leq \text{UVP Transfer Voltage} \leq 12.5$ · $10.5 \leq \text{OVP Transfer voltage} \leq 15.5$ · $\text{OVP Transfer voltage} - \text{UVP Transfer Voltage} > 0.2$. If the above conditions are not met, the setting will be invalid.

When the Shutdown Volt \geq UVP Transfer Voltage in the W command, the UVP Transfer Voltage setting value is as follows:
The 12V setting is Shutdown Volt+0.5V, the 24V setting is Shutdown Volt+1V, and the 48V setting is Shutdown Volt+2V.

If the UVP Transfer Voltage is set \geq the OVP Transfer voltage, the OVP Transfer voltage is set as follows:
12V setpoint is UVP Transfer Voltage +0.5V, 24V setpoint is UVP Transfer Voltage +1V, The 48V setting is UVP Transfer Voltage+2V.

3. Q Instruction transmission

The NTS-750-248UN model is used as an example to read the inverter status

request instructions: 51 0D

Return instruction: 28 32 33 30 20 30 32 35 20 34 38 2E 33 20 30 37 35 20 32 30 2E 30 20 30 30 30 20 35 30 2E 30 20 30 30 30 20 30 32 33 20 31 30 30 30 30 30 30 30 30 30 30 30 30 30 29 0D

Request instruction interpretation:

Digit position	0	1
Input order	51	0D
Function	Q instruction confirmation	End mark
Explain	Q instruction write	End of instruction

Return instructions explained:

Digit position	0	1-3	4	5-7	8	9-12	13	14-16
Return instruction	28	32 33 30	20	30 32 35	20	34 38 2E 33	20	30 37 35
Function	(Output voltage	spacing	output power (%)	spacing	input voltage	spacing	battery capacity
Explain	(230V	spacing	0<~<=30%	spacing	48.3V	spacing	51%<~<=75%

17	18~21	22	23~25	26	27~30	31	32~34	35	36~38
20	35 30 2E 30	20	30 30 30	20	35 30 2E 30	20	30 30 30	20	30 32 33
Spacing	temperature	Spacing	input the mains voltage	Spacing	output voltage frequency	Spacing	DC Bus voltage	Spacing	output power (percentage value)
Spacing	20.0°C	Spacing	0V	Spacing	50Hz	Spacing	0V	Spacing	23%

5.4.2 Communication Practices

Examples of RS-232/UART communications are provided below

1. Connect PIN3, PIN5, and PIN2 of the back-end controller DB9 to Rx(PIN2),GND(PIN3), and Tx(PIN4) of the RJ11 communication terminals of the NTS-750-248UN.
2. The communication entity layer is set as follows:

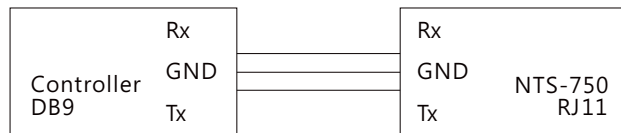

Control	Setting
Baud Rate	9600
Data Bits	8
Stop Bit	1
Parity	None
Flow Control	None

39	40	41	42	43	44	45	46	47	48
20	31	30	30	30	30	30	30	30	30
spacing	INVERTER Mode detection	Bypass Mode detection	Utility Power detection	Utility Charge detection	Solar Charger detection	Saving Mode detection	Battery Exhausted Mode detection	Shutdown Mode detection	Battery OVP detection
spacing	In inverter mode	Not in Bypass mode	No utility Power supply	Utility Charge disable	Solar Charger disable	Not in Saving Mode	Not in Battery Exhausted Mode	Not in Shutdown Mode	Not in Battery OVP

49	50	51	52	53	54	55	56	57	58
30	30	30	30	30	30	30	30	30	30
Remote Shutdown	OLP 100~115%	OLP 115%~150%	OLP 150%~	OTP	INV UVP	INV OVP	INV Fault	EEPROM error code	System Shutdown
Remote shutdown is not enabled	The load does not reach 100~115% of the rated load	The load does not reach 100~115% of the rated load	The load does not reach more than 150% of the rated load	The power supply is not in over temperature protection mode	The power supply is not in over temperature protection mode	The output voltage is normal, and the OVP function is not triggered	The power supply works normally without fault	Data storage works properly without failure	The system works properly and is not shut down

59	60
29	0D
)	End mark
)	End of return

4. C Instruction transmission

The NTS-750-248UN model is used as an example to perform the remote shutdown command.

Request instruction : 43 31 30 30 30 30 30 30 30 30 30 30 30 30 30 0D

Return instruction : 43

Request instruction interpretation :

Digit position	0	1	2	3-15	16
Return instruction	43	31	30	30	0D
Function	C instruction confirmation	Shut down	Turn on INVERTER	No special functions, reserved for other locations	End mark
Explain	C instruction write	Shutdown instruction on	Power-on instruction off		End of instruction

Return instructions explained :

Digit position	0
Return instruction	43
Function	C command return
Explain	C instruction in effect

5. V instruction transmission

In the example of NTS-750-248UN, the output frequency is changed to 60Hz.

(1) First unlock with the pu command

Input instruction : 70 55 0D

No return

(2) Input instruction : 56 32 33 30 20 30 36 30 01 A1 0D

Return instruction : 23 32 33 30 20 30 36 30 01 6E 0D

Input instruction interpretation:

Digit position	0	1-3	4	5-7	8-9	10
Return instruction	56	32 33 30	20	30 36 30	01 A1	0D
Function	V instruction confirmation	Output voltage setting	Spacing	Frequency setting	Check	End mark
Explain	V instruction write	230V	Spacing	60Hz	Check bit	End of instruction

Output instruction interpretation :

Digit position	0	1-3	4	5-7	8-9	10
Return instruction	23	32 33 30	20	30 36 30	01 6E	0D
Function	(Output voltage reading	Spacing	Frequency reading	Check	End mark
Explain	(230V	Spacing	60Hz	Check bit	End of instruction

6. I instruction transmission

Take NTS-750-248UN model as an example to read inverter information.

Request instruction : 49 0D

Return instruction : 23 03 00 05 30 30 2E 30 20 30 30 2E 30 20 34 34 2E 30 20 34 30 2E 30 20 30 30 2E 30 20 4D 45 41 4E 57 45 4C 4C 20 20 20 4C 4F 43 2D 30 31 32 33 34 35 36 37 38 39 20 20 20 20 20 20 52 45 56 3A 30 31 2E 34 20 20 4E 54 53 2D 30 37 35 30 2D 32 34 38 20 20 31 20 30 30 2F 30 30 2F 30 30 30 12 6C 0D

Request instruction interpretation:

Digit position	0	1
Return instruction	49	0D
Function	W instruction confirmation	End mark
Explain	W instruction write	End of instruction

Return instructions explained :

Digit position	0	1	2	3	4-7	8	9-12	13
Return instruction	23	03	00	05	30 30 2E 30	20	30 30 2E 30	20
Function	(Voltage/frequency gear	Saving Mode	Mode code	Equalization Volt.	Spacing	Floating Volt.	Spacing
Explain	(240V/50Hz	Power saving mode off	Mode 248	0V	Spacing	0V	Spacing

14-17	18	19-22	23	24-27	28	29-38
34 34 2E 30	20	34 30 2E 30	20	30 30 2E 30	20	4D 45 41 4E 57 45 4C 4C 20 20
Alarm Volt.	Spacing	Shutdown Volt	Spacing	Shutdown Volt	Spacing	Manufacture Country
44.0V	Spacing	40.0V	Spacing	0V	Spacing	MEANWELL

39	40-58	59	60-68
20	4C 4F 43 2D 30 31 32 33 34 35 36 37 38 39 20 20 20 20 20	20	52 45 56 3A 30 31 2E 34 20
Spacing	Serial Number	Spacing	Revision
Spacing	LOC-12345678	Spacing	REV:01.4

69	70-82	83	84	85	86-95
20	4E 54 53 2D 30 37 35 30 2D 32 34 38 20	20	31	20	30 30 2F 30 30 30 2F 30 30 30 30
Spacing	Model Name	Spacing	Battery First Flag	Spacing	Date
Spacing	NTS-0750-248	Spacing	Enable	Spacing	00/00/0000

96-97	98
12 6C	0D
Check	End mark
check bit	End of instruction

7. W instruction transmission

In the example of NTS-750-248UN, the W command is used to change the alarm voltage to 42.0V.

Request instruction: 57 03 00 05 36 30 2E 30 20 36 30 2E 30 20 34 32 2E 30 20 34 30 2E 30 20 36 30 2E 30 20 4D 45 41 4E 57 45 4C 4C 20 20 20 4C 4F 43 2D 30 31 32 33 34 35 36 37 38 39 20 20 20 20 20 20 52 45 56 3A 30 31 2E 34 20 20 4E 54 53 2D 30 37 35 30 2D 32 34 38 20 20 31 20 30 30 2F 30 30 2F 30 30 30 12 B0 0D

Return instruction: 23 03 00 05 30 30 2E 30 20 30 30 2E 30 20 34 32 2E 30 20 34 30 2E 30 20 30 30 2E 30 20 4D 45 41 4E 57 45 4C 4C 20 20 20 4C 4F 43 2D 30 31 32 33 34 35 36 37 38 39 20 20 20 20 20 20 52 45 56 3A 30 31 2E 34 20 20 4E 54 53 2D 30 37 35 30 2D 32 34 38 20 20 31 20 30 30 2F 30 30 2F 30 30 30 12 6A 0D

Request instruction interpretation:

Digit position	0	1	4	3	4-7	8	13	13
Return instruction	23	03	00	05	36 30 2E 30	20	20	20
Function	(Voltage/ frequency gear	Saving Mode	Mode code	Equalizati on Volt.	Spacing	spacing	spacing
Explain	(240V/50Hz	Power saving mode off	Model 248	60V	48.3V	Spacing	Spacing

14-17	18	19-22	23	24-27	28	29-38
34 32 2E 30	20	34 30 2E 30	20	36 30 2E 30	20	4D 45 41 4E 57 45 4C 4C 20 20
Alarm Volt.	Spacing	Shutdown Volt	Spacing	Shutdown Volt	Spacing	Manufacture Country
42.0V	Spacing	40.0V	Spacing	60.0V	Spacing	MEANWELL

39	40-58	59	60-68
20	4C 4F 43 2D 30 31 32 33 34 35 36 37 38 39 20 20 20 20	20	52 45 56 3A 30 31 2E 34 20
Spacing	Serial Number	Spacing	Revision
Spacing	LOC-123456789	Spacing	REV:01.4

69	70-82	83	84	85	86-95
20	4E 54 53 2D 30 37 35 30 2D 32 34 38 20	20	31	20	30 30 2F 30 30 30 2F 30 30 30 30
Spacing	Model Name	Spacing	Battery First Flag	Spacing	Date
Spacing	NTS-0750-248	Spacing	Enable	Spacing	00/00/0000

96-97	98
12 6C	0D
Check	end mark
Check bit	End of instruction

For the W return instruction, refer to the I return instruction.

8 U instruction transmission

In the example of NTU-1700-148UN · The U command reads the inverter battery UVP and OVP voltage switching points (Before using the U command, you need to set the Battery First Flag to 1 via the W command, or operate the DIP SW to enable the battery priority function)

request instructions : 55 0D

Return instruction : 23 34 34 2E 30 20 35 37 2E 36 20 30 30 2E 30 20 30 30 2E 30 20 30 30 2E 30 20 30 30 2E 30 05 51 0D

Request instruction interpretation :

Digit position	0	1
Return instruction	55	0D
Function	U instruction confirmation	End mark
Explain	U instruction write	End of instruction

Return instructions explained :

Return instruction : 23 34 34 2E 30 20 35 37 2E 36 20 30 30 2E 30 20 30 30 2E 30 20 30 30 2E 30 05 51 0D

Digit position	0	1 ~ 4	5	6 ~ 9	10	11~14	15	16~19
Return instruction	23	34 34 2E 30	20	35 37 2E 36	20	30 30 2E 30	20	30 30 2E 30
Function	#	Battery UVP switching point voltage setting	Spacing	Battery OVP switching point voltage setting	Spacing	No special functions, reserved for other locations.	Spacing	No special functions, reserved for other locations.
Explain	#	44.0V	Spacing	57.6V	Spacing		Spacing	
Digit position	20	21~24	25	26~29	30 31	32		
Return instruction	20	30 30 2E 30	20	30 30 2E 30	05 51	0D		
Function	Spacing	No special functions, reserved for other locations.	Spacing	No special functions, reserved for other locations.	Check	End mark		
Explain	Spacing		Spacing		Check bit	End of instruction		

In the example of NTU-1700-148UN · The U command is written to the inverter UVP voltage switching point of 44.0V and the OVP voltage switching point of 57.6V.

request instructions: 55 34 34 2E 30 20 35 37 2E 36 20 30 30 2E 30 20 30 30 2E 30 20 30 30 2E 30 05 83 0D

Return instruction : 23 34 34 2E 30 20 35 37 2E 36 20 30 30 2E 30 20 30 30 2E 30 20 30 30 2E 30 05 1E 0D

Request instruction interpretation :

Digit position	0	1 ~ 4	5	6 ~ 9	10	11~14	15	16~19
Return instruction	55	34 34 2E 30	20	35 37 2E 36	20	30 30 2E 30	20	30 30 2E 30
Function	U instruction confirmation	Battery UVP switching point voltage setting	Spacing	Battery OVP switching point voltage setting	Spacing	No special functions, reserved for other locations.	Spacing	No special functions, reserved for other locations.
Explain	U instruction confirmation	44.0V	Spacing	57.6V	Spacing		Spacing	
Digit position	20	21~24	25	26~29	30 31	32		
Return instruction	20	30 30 2E 30	20	30 30 2E 30	05 83	0D		
Function	Spacing	No special functions, reserved for other locations.	Spacing	No special functions, reserved for other locations.	Check	End mark		
Explain	Spacing		Spacing		Check bit	End of instruction		

Return instructions explained

Digit position	0	1 ~ 4	5	6 ~ 9	10	11~14	15	16~19
Return instruction	23	34 34 2E 30	20	35 37 2E 36	20	30 30 2E 30	20	30 30 2E 30
Function	#	Battery UVP switching point voltage setting	Spacing	Battery OVP switching point voltage setting	Spacing	No special functions, reserved for other locations.	Spacing	No special functions, reserved for other locations.
Explain	#	44.0V	Spacing	57.6V	Spacing		Spacing	
Digit position	20	21~24	25	26~29	30 31	32		
Return instruction	20	30 30 2E 30	20	30 30 2E 30	05 1E	0D		
Function	Spacing	No special functions, reserved for other locations.	Spacing	No special functions, reserved for other locations.	Check	End mark		
Explain	Spacing		Spacing		Check bit	End of instruction		

5.5 UPS Mode(only for NTU series)

5.5.1 Explanation of UPS mode

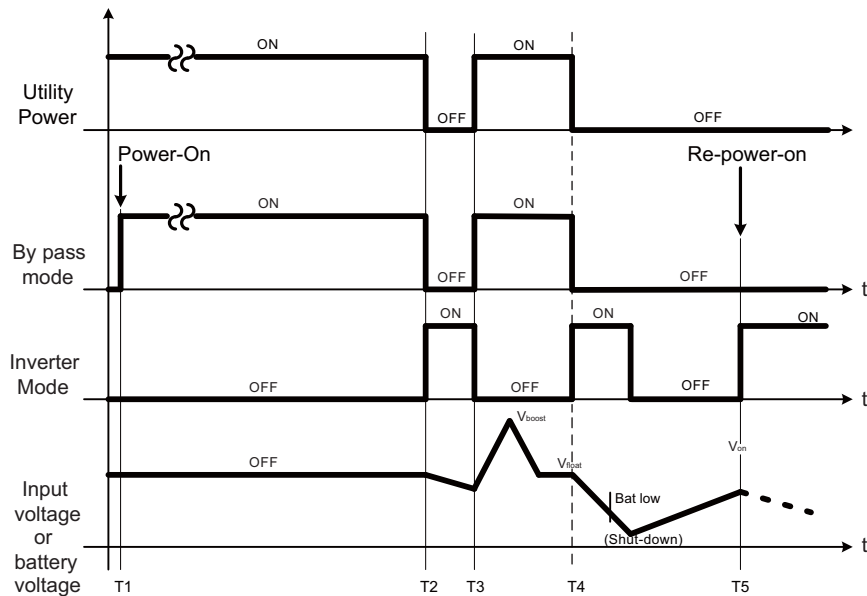

T1: When the user turns on the NTU, if the mains voltage is normal, the NTU will enter the bypass mode, and the mains voltage will supply the load. At this time, the battery is fully charged.

T2: If the mains voltage momentarily fails to supply AC output or the mains voltage momentarily exceeds the range of $\pm 16\%$ of the NTU set output, NTU will immediately switch to inverter mode so that the customer's equipment will not have blackout phenomenon due to the instability of the mains voltage. Take the NTU-1200-124 (the preset output voltage is 110Vac) as an example: When the mains voltage is greater than 127.6Vac or less than 92.4Vac, the NTU-1200-124 will enter the inverter mode for power supply, at which time the battery begins to provide energy to the inverter to achieve backup function.

T3: If the mains has returned to normal or the mains voltage is within the range of $\pm 13\%$ of the NTU set output, the NTU will switch to Bypass mode again, and the mains will supply power to the load, at which time the battery can be charged through an external charger.

T4: When the battery string voltage is consumed to the lower limit of the inverter output voltage, and the power is off. At this time, the external battery charger cannot provide energy, so the inverter will continue to act to guide the battery voltage below the lower limit of the operating voltage.

T5: When the external battery voltage is restored due to the mains and the external charger charges the battery voltage to the operating voltage of the inverter, the inverter automatically restarts and operates.

T6: When the NTU-1700 series or higher power models work in Bypass mode, and the mains supply power to the load end, connect the inverter to the battery string to start fan heating.

5.5.2 UPS mode configuration reference figure

NTU-1200/1700/2200/3200 must be used with the charger to maintain the working quality of the UPS mode. When the NTU works in Bypass mode, the charger ensures that the battery voltage can provide sufficient power for the inverter mode when the mains is abnormal. When the mains returns to normal work from the abnormal state, the charger can also make up for the power lost in the inverter mode. When connecting the charger, select the wire with the appropriate diameter according to the output current to connect the battery and the inverter. For details, see Table 3-1 Cable Usage suggestions

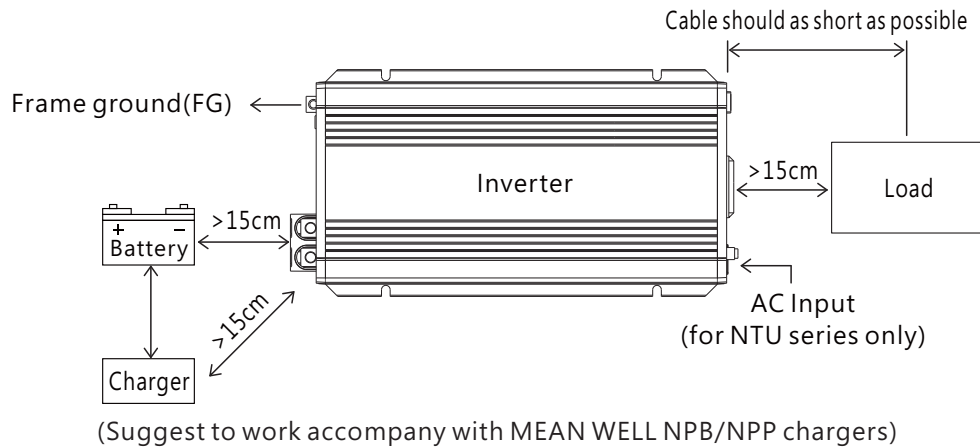

6. Protections and Failure Correction

6.1 Protection Function:

AC Output Protection :

- **AC Output Over Load Protection :**
When overloaded, the inverter is able to supply power for a period of time. If the load does not drop back to the normal range, the OLP will be triggered and turn off the inverter. Once the OLP condition is removed, re-power on the inverter to start operation again.
- **AC Output Short Circuit Protection :**
When short-circuit occurs or the load increasing significantly, the inverter will turn off for protection. After removing the fault condition, re-power on the inverter to start operation.

DC Input Protection :

- **DC Polarity Protection :**
When connecting the DC polarity reversely, the internal fuse will blow for protection. The unit then must return to MEAN WELL's distributor for further support.
- **Low DC Input Protection :**
When DC input is lower than the operating range, inverter will turn off automatically for protection.
- **Over Voltage of DC Input :**
When the voltage of DC input over the operating range, the inverter will turn off for protection. After the fault condition is removed, inverter will restart automatically. If the inverter cannot operate normally afterwards, it represents that the inverter is damaged. Please return the unit to MEAN WELL's distributor if needed.

Inverter Protection :

- **Over temperature protection(OTP) :**
When the temperature inside the inverter raise to a certain level, the inverter will turn off for protection. After the temperate dropped back to operating range, re-power the inverter for operation.

6.2 Failure Correction

Once failure condition occurs, the LED on panel of inverter will show different LED light for indication. Fault condition can be separated into 4 categories, AC output protection, DC input protection, over temperature protection or other. Please refer to the following table for fault indication and correction. If the fault condition cannot be solved, please contact MEAN WELL's distributor for further assistance.

fault signal	Possible cause	Suggestions for Fault correction
Status ● DC Input ○ Load ☀	Over load protection	Check if the load requires high startup current, such as inductive or capacitance loads. After the fault condition is remover, re-power the inverter for operation.
	Short circuit protection	Check if the load requirement exceed the rated value or if the circuit is shorted.
Status ● DC Input ☀ Load ○	Aged battery or malfunction	Change a new battery
	Wrong battery capacitance	Re check if the parameter of battery suits inverter's operating parameter
Status ● DC Input ☀ Load ☀	Over temperature protection	Remove subject away from venthole if any. If it's due to high ambient, please lower the temperate or load to proceed. After the fault condition is remove, re-power inverter for operation.
Status ☀ DC Input ○ Load ○	Other fault condition that's not defined	Contact MEAN WELL's distributor

Note: ● Light

☀ Flash

○ Light off

7. Warranty

This product provide three years warranty under normal usage. Do not replace parts or any form of modification to the product in order to keep the warranty effectively.

※ MEAN WELL posses the right to adjust the content of this manual. Please refer to the latest version of our manual on our website. <https://www.meanwell.com>



8. Environmental declaration information

https://www.meanwell.com//Upload/PDF/RoHS_PFOS.pdf
https://www.meanwell.com//Upload/PDF/REACH_SVHC.pdf
https://www.meanwell.com//Upload/PDF/Declaration_RoHS-E.pdf

明緯企業股份有限公司

MEAN WELL ENTERPRISES CO., LTD.

248 新北市五股區五權三路28號

No.28, Wuquan 3rd Rd., Wugu Dist., New Taipei City 248, Taiwan

Tel:886-2-2299-6100 Fax:886-2-2299-6200

<http://www.meanwell.com> E-mail:info@meanwell.com