

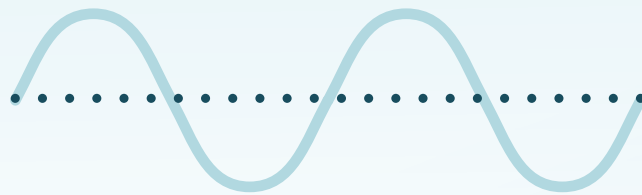

NTS & NTU Series

User Manual



True Sine Wave Inverter

• High Reliable Inverter •

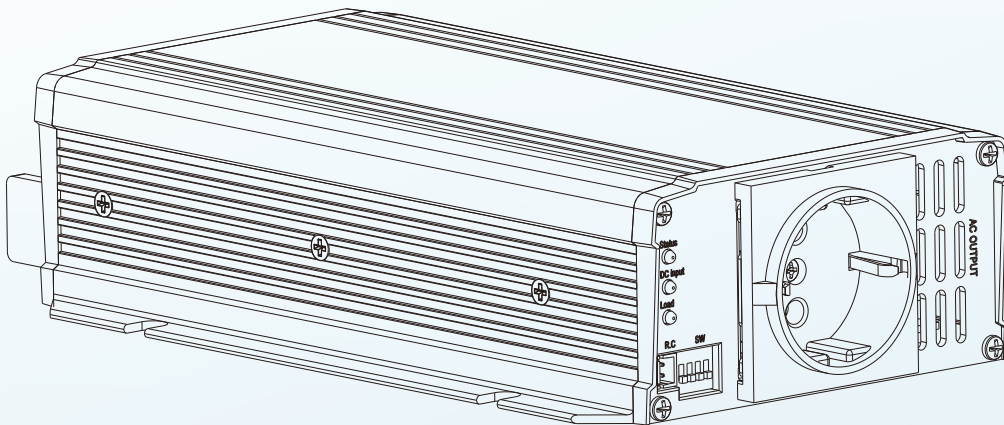

NTS/NTU系列為明緯新一代高可靠離網型DC-AC純正弦波逆變器，全家族有NTS-250P/400P、NTS-300/450/750/1200/1700/2200/3200、NTU-1200/1700/2200/3200等齊全系列瓦數。全家族系列產品皆運用全數位化智能芯片設計，擁有小型化、高效化、智能化三大特色，主要特點有：瞬間峰值帶載能力可達2倍瓦數，可透過前面板DIP S.W彈性自調交流輸出電壓/頻率/省電模式(待機空耗最高僅1.5W)、工作效率最高達93%、可操作於-25~+70°C使用環境受限少，內建遠端搖控ON/OFF功能、可監控電池電壓及逆變器使用負載狀態(需搭用IRC1/2/3)、多重智能保護功能且通過了CB/DEKRA/E13/EAC/UL/RCM/FCC/CE/UKCA等國際認證，使用安全有保障。高信賴度零件與架購設計，非常適用於家用、車用、遊艇、偏遠地區無電力網或UPS緊急備援等場合，常見應用負載如：照明、空調、冰箱、吹風機、微波爐、電腦、電視、手持電動工具、馬達類設備、移動式交流電源.....等。

目錄

1.操作安全注意事項	1	6.異常排除	58
2.產品簡介	2	6.1 保護功能	58
2.1 機型命名	2	6.2 異常排除	59
2.2 產品特點	2	7.保固	60
2.3 電氣規格表	3	8.環境宣告資訊	61
2.4 安規一覽表	16		
2.5 減額曲線	17		
2.6 產品機構圖	18		
3.安裝說明	24		
3.1 安裝注意事項	24		
3.2 裝配參考圖	24		
3.3 安裝步驟	25		
3.4 連接電池配線選用	25		
3.5 電池組配置建議	26		
3.6 GFCI 插座	26		
4.面板與燈號顯示	27		
4.1 AC輸出側	27		
4.2 DC輸入側	29		
4.3 LED燈號說明	30		
5.功能設定說明	31		
5.1 輸出電壓、頻率、省電 模式、遙控設定	31		
5.2 功能差異表	32		
5.3 IRC1/IRC2/IRC3遠端 監控模組	33		
5.4 RS-232/UARA通訊	34		
5.5 UPS模式(僅NTU系列)	56		

1. 操作安全注意事項

- 本機器內含高電壓線路具潛在危險性，請由專業人員進安裝，如有異常或無法正常使用，請勿自行打開逆變器外蓋。
- 請勿將逆變器放置於潮濕環境或近水處。
- 請勿將逆變器置於高溫環境、太陽直射處或近火源處。
- 更換電池時，請採用相同品牌及相同型號之電池設備。嚴禁採用不同品牌或不同容量之電池同時串並聯使用。
- 電池或電池組請勿靠近火源。
- 請保持逆變器前、後之進氣或排氣的暢通。(請保持至少15cm以上)。
- 請勿於逆變器機體上堆放其他物品，避免影響逆變器之散熱能力。
- 如將逆變器直接連接至車輛電池，引擎發動前請先確認逆變器需為關機狀態。
- 安裝時應對交流輸出電路提供支路額定過電流保護。

2. 產品簡介

2.1 機型命名

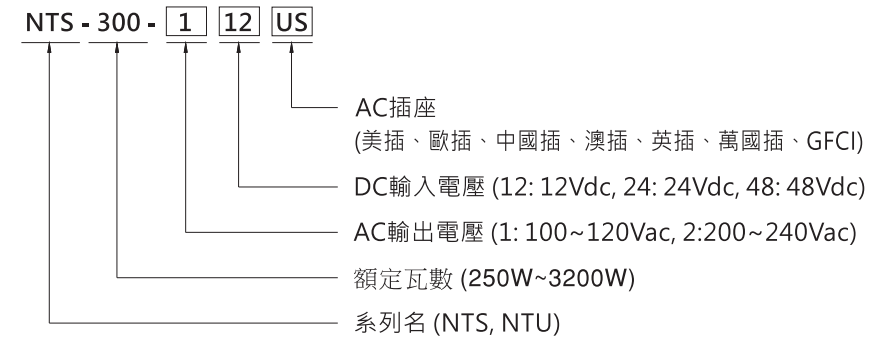

2.2 產品特點

- 採全數位化設計，具智能監控、高效省電、輕量化
- 採純正弦波輸出(THD<3%)
- 瞬間輸出功率最大可達1.7~2倍(依機型)
- 可自調AC輸出電壓、頻率及省電模式
- 多重智能保護功能
 - DC輸入側：逆接/電壓過低或電池過放/電壓過高
 - AC輸出側：短路/超載/過溫
- LED 燈號說明：狀態/DC輸入/負載顯示/AC輸入
- 內建遠端遙控端點
- 可另購遠端監控器(IRC1/2/3，限用於750~3200W機型)
- 具備不斷電功能(僅NTU系列)
- DC寬壓輸入，適用鉛酸或鋰電池
- 通過CB/DEKRA/E13/EAC/UL/RCM/FCC/CE/UKCA 國際認證
- 3年長效保固

2.3 電氣規格表

NTS-250P系列

MODEL	NTS-250P-112	NTS-250P-124	NTS-250P-148	NTS-250P-212	NTS-250P-224	NTS-250P-248			
OUTPUT	RATED POWER(Continuous)		250W						
	OVER RATED POWER(3 Min.)		287.5W						
	PEAK POWER(10 Sec.)		375W						
	SURGE POWER(30 Cycles)		500W						
	AC VOLTAGE		Default setting set at 110VAC 100 / 110 / 115 / 120Vac selectable by DIP S.W		Default setting set at 230VAC 200 / 220 / 230 / 240Vac selectable by DIP S.W				
	FREQUENCY		Default setting set at 60Hz±0.1Hz 50/60Hz selectable by DIP S.W		Default setting set at 50Hz±0.1Hz 50/60Hz selectable by DIP S.W				
	WAVEFORM <small>Note.1</small>		True sine wave (THD<3%)						
	AC REGULATION		±3.0% at rated input voltage						
	LED STATUS		Please refer to section 3.4 of installation manual						
INPUT	BAT. VOLTAGE		12V	24V	48V	12V	24V	48V	
	VOLTAGE RANGE (Typ.)		10 ~ 16.5Vdc	20 ~ 33Vdc	40 ~ 66Vdc	10 ~ 16.5Vdc	20 ~ 33Vdc	40 ~ 66Vdc	
	DC CURRENT (Typ.)		25A	13A	7A	25A	13A	7A	
	NO LOAD DISSIPATION (Typ.)	NON-SAVING MODE	10W	10W	12W	10W	10W	12W	
		SAVING MODE	Default disable, ≤1.2W ~ 1.5W by models @ auto detec AC output load ≤10W will be changed to saving mode						
	OFF MODE CURRENT DRAW		<1mA at battery ~DC input must be disconnected						
	EFFICIENCY (Typ.) <small>Note.1</small>		91%	91%	92%	92%	93%	93%	
	BATTERY TYPES		Lead Acid or li-ion						
PROTECTION	DC INPUT	FUSE (INTERNAL)		30A*2	30A*1	10A*2	30A*2	30A*1	10A*2
		LOW	ALARM	11±0.3Vdc	22±0.5Vdc	44±1Vdc	11±0.3Vdc	22±0.5Vdc	44±1Vdc
			SHUTDOWN	10±0.3Vdc	20±0.5Vdc	40±1Vdc	10±0.3Vdc	20±0.5Vdc	40±1Vdc
			RESTART	12.5±0.3Vdc	25±0.5Vdc	50±1Vdc	12.5±0.3Vdc	25±0.5Vdc	50±1Vdc
		HIGH	ALARM	15.5±0.3Vdc	31±0.5Vdc	62±1Vdc	15.5±0.3Vdc	31±0.5Vdc	62±1Vdc
			SHUTDOWN	16.5±0.3Vdc	33±0.5Vdc	66±1Vdc	16.5±0.3Vdc	33±0.5Vdc	66±1Vdc
	RESTART		15±0.3Vdc	30±0.5Vdc	60±1Vdc	15±0.3Vdc	30±0.5Vdc	60±1Vdc	
	BAT. POLARITY		By internal fuse open						
	AC OUTPUT	OVER TEMPERATURE		Protection type : Shut down o/p voltage, re-power on to recover					
		OUTPUT SHORT		Protection type : Shut down o/p voltage, re-power on to recover					
OVER LOAD (Typ.)		105 ~ 115% load for 180 sec., 115% ~ 150% load for 10 sec. Protection type : Shut down o/p voltage, re-power on to recover							
FUNCTION	REMOTE CONTROL DRY CONTACT		Power ON-OFF remote control by front panel dry contact connector (by RELAY) Open : Normal work ; Short : Remote off						
ENVIRON-MENT	WORK TEMP.		-20 ~ +70°C (Refer to "Derating curve")						
	WORKING HUMIDITY		20 ~ 90% RH non-condensing						
	STORAGE TEMP., HUMIDITY		-30 ~ +70°C / -22 ~ +158°F, 10 ~ 95% RH non-condensing						
	VIBRATION		10 ~ 500Hz, 3G 10min./1cycle, 60min. each along X, Y, Z axes						
OTHER	MTBF		279K hrs min. Telcordia TR/SR-332 (Bellcore); 84K hrs min. MIL-HDBK-217F (25°C)						
	DIMENSION		186*100.5*32mm (L*W*H)						
	PACKING		0.75Kg; 18pcs/ 14.5Kg/ 0.97CUFT						

NTS-400P系列

MODEL	NTS-400P-112	NTS-400P-124	NTS-400P-148	NTS-400P-212	NTS-400P-224	NTS-400P-248			
OUTPUT	RATED POWER(Continuous)		400W						
	OVER RATED POWER(3 Min.)		460W						
	PEAK POWER(10 Sec.)		600W						
	SURGE POWER(30 Cycles)		800W						
	AC VOLTAGE		Default setting set at 110VAC 100 / 110 / 115 / 120Vac selectable by DIP S.W		Default setting set at 230VAC 200 / 220 / 230 / 240Vac selectable by DIP S.W				
	FREQUENCY		Default setting set at 60Hz±0.1Hz 50/60Hz selectable by DIP S.W		Default setting set at 50Hz±0.1Hz 50/60Hz selectable by DIP S.W				
	WAVEFORM <small>Note.1</small>		True sine wave (THD<3%)						
	AC REGULATION		±3.0% at rated input voltage						
	LED STATUS		Please refer to section 3.4 of installation manual						
INPUT	BAT. VOLTAGE		12V	24V	48V	12V	24V	48V	
	VOLTAGE RANGE (Typ.)		10 ~ 16.5Vdc	20 ~ 33Vdc	40 ~ 66Vdc	10 ~ 16.5Vdc	20 ~ 33Vdc	40 ~ 66Vdc	
	DC CURRENT (Typ.)		40A	20A	10A	40A	20A	10A	
	NO LOAD DISSIPATION (Typ.)	NON-SAVING MODE	10W	10W	12W	10W	10W	12W	
		SAVING MODE	Default disable, ≤1.2W ~ 1.5W by models @ auto detec AC output load ≤10W will be changed to saving mode						
	OFF MODE CURRENT DRAW		<1mA at battery ~DC input must be disconnected						
	EFFICIENCY (Typ.) <small>Note.1</small>		89%	91%	91%	91%	93%	93%	
	BATTERY TYPES		Lead Acid or li-ion						
PROTECTION	DC INPUT	FUSE (INTERNAL)		40A*2	30A*2	10A*2	40A*2	30A*2	10A*2
		LOW	ALARM	11±0.3Vdc	22±0.5Vdc	44±1Vdc	11±0.3Vdc	22±0.5Vdc	44±1Vdc
			SHUTDOWN	10±0.3Vdc	20±0.5Vdc	40±1Vdc	10±0.3Vdc	20±0.5Vdc	40±1Vdc
			RESTART	12.5±0.3Vdc	25±0.5Vdc	50±1Vdc	12.5±0.3Vdc	25±0.5Vdc	50±1Vdc
		HIGH	ALARM	15.5±0.3Vdc	31±0.5Vdc	62±1Vdc	15.5±0.3Vdc	31±0.5Vdc	62±1Vdc
			SHUTDOWN	16.5±0.3Vdc	33±0.5Vdc	66±1Vdc	16.5±0.3Vdc	33±0.5Vdc	66±1Vdc
	RESTART		15±0.3Vdc	30±0.5Vdc	60±1Vdc	15±0.3Vdc	30±0.5Vdc	60±1Vdc	
	BAT. POLARITY		By internal fuse open						
	AC OUTPUT	OVER TEMPERATURE		Protection type : Shut down o/p voltage, re-power on to recover					
		OUTPUT SHORT		Protection type : Shut down o/p voltage, re-power on to recover					
OVER LOAD (Typ.)		105 ~ 115% load for 180 sec., 115% ~ 150% load for 10 sec. Protection type : Shut down o/p voltage, re-power on to recover							
FUNCTION	REMOTE CONTROL DRY CONTACT		Power ON-OFF remote control by front panel dry contact connector (by RELAY) Open : Normal work ; Short : Remote off						
ENVIRON-MENT	WORK TEMP.		-20 ~ +70°C (Refer to "Derating curve")						
	WORKING HUMIDITY		20 ~ 90% RH non-condensing						
	STORAGE TEMP., HUMIDITY		-30 ~ +70°C / -22 ~ +158°F, 10 ~ 95% RH non-condensing						
	VIBRATION		10 ~ 500Hz, 3G 10min./1cycle, 60min. each along X, Y, Z axes						
OTHER	MTBF		278.7K hrs min. Telcordia TR/SR-332 (Bellcore); 84K hrs min. MIL-HDBK-217F (25°C)						
	DIMENSION		186*100.5*32mm (L*W*H)						
	PACKING		0.75Kg; 18pcs/ 14.5Kg/ 0.97CUFT						

NTS-300系列

MODEL		NTS-300-112 <input type="checkbox"/> NTS-300-124 <input type="checkbox"/> NTS-300-148 <input type="checkbox"/>		NTS-300-212 <input type="checkbox"/> NTS-300-224 <input type="checkbox"/> NTS-300-248 <input type="checkbox"/>					
		<input type="checkbox"/> = US, GFCI, UN		<input type="checkbox"/> = EU, CN, AU, UK, UN					
OUTPUT	RATED POWER(Continuous)	300W							
	OVER RATED POWER(3 Min.)	345W							
	PEAK POWER(10 Sec.)	450W							
	SURGE POWER(30 Cycles)	600W							
	AC VOLTAGE	Default setting set at 110VAC		Default setting set at 230VAC					
	FREQUENCY	100 / 110 / 115 / 120Vac selectable by DIP S.W		200 / 220 / 230 / 240Vac selectable by DIP S.W					
	WAVEFORM	Note.1 True sine wave (THD<3%)							
AC REGULATION	±3.0% at rated input voltage								
FRONT PANEL LED	Please refer to section 3.4 of installation manual								
INPUT	BAT. VOLTAGE	12V	24V	48V	12V	24V	48V		
	VOLTAGE RANGE (Typ.)	10 ~ 16.5Vdc	20 ~ 33Vdc	40 ~ 66Vdc	10 ~ 16.5Vdc	20 ~ 33Vdc	40 ~ 66Vdc		
	DC CURRENT (Typ.)	30A	15A	8A	30A	15A	8A		
	NO LOAD	10W	10W	12W	10W	10W	12W		
	DISSIPATION (Typ.)	NON-SAVING MODE	Default disable, ≤1.2W ~ 1.5W by models @ auto detec AC output load ≤10W will be changed to saving mode						
		SAVING MODE	1.2W	1.3W	1.5W	1.2W	1.3W	1.5W	
	OFF MODE CURRENT DRAW	≤1mA							
	EFFICIENCY (Typ.)	Note.1	90%	92%	92%	92%	93%	93%	
BATTERY TYPES	Lead Acid or li-ion								
PROTECTION	DC INPUT	FUSE (INTERNAL)	30A*2	30A*1	10A*2	30A*2	30A*1	10A*2	
		LOW	ALARM	11±0.3Vdc	22±0.5Vdc	44±1Vdc	11±0.3Vdc	22±0.5Vdc	44±1Vdc
			SHUTDOWN	10±0.3Vdc	20±0.5Vdc	40±1Vdc	10±0.3Vdc	20±0.5Vdc	40±1Vdc
			RESTART	12.5±0.3Vdc	25±0.5Vdc	50±1Vdc	12.5±0.3Vdc	25±0.5Vdc	50±1Vdc
		HIGH	ALARM	15.5±0.3Vdc	31±0.5Vdc	62±1Vdc	15.5±0.3Vdc	31±0.5Vdc	62±1Vdc
			SHUTDOWN	16.5±0.3Vdc	33±0.5Vdc	66±1Vdc	16.5±0.3Vdc	33±0.5Vdc	66±1Vdc
	RESTART		15±0.3Vdc	30±0.5Vdc	60±1Vdc	15±0.3Vdc	30±0.5Vdc	60±1Vdc	
	BAT. POLARITY	By internal fuse open							
	AC OUTPUT	OVER TEMPERATURE	Protection type : Shut down o/p voltage, re-power on to recover						
		OUTPUT SHORT	Protection type : Shut down o/p voltage, re-power on to recover						
		OVER LOAD (Typ.)	105 ~ 115% load for 180 sec., 115% ~ 150% load for 10 sec. Protection type : Shut down o/p voltage, re-power on to recover						
		GFCI PROTECTION	Design refer to UL458 (Only for "GFCI" AC socket, by request)		None				
FUNCTION		REMOTE CONTROL DRY CONTACT	Power ON-OFF remote control by front panel dry contact connector (by RELAY) Open : Normal work ; Short : Remote off						
ENVIRON-MENT	WORK TEMP.	-25 ~ +65°C (Refer to "Derating curve")							
	WORKING HUMIDITY	20 ~ 90% RH non-condensing							
	STORAGE TEMP., HUMIDITY	-30 ~ +70°C / -22 ~ +158°F, 10 ~ 95% RH non-condensing							
	VIBRATION	10 ~ 500Hz, 3G 10min./1cycle, 60min. each along X, Y, Z axes							
OTHER	MTBF	281.9K hrs min. Telcordia TR/SR-332 (Bellcore); 85.3K hrs min. MIL-HDBK-217F (25°C)							
	DIMENSION	210*130*55mm (L*W*H)							
	PACKING	1.3Kg; 8pcs/ 11.4Kg/ 1.74CUFT							

NTS-450系列

MODEL		NTS-450-112 <input type="checkbox"/> NTS-450-124 <input type="checkbox"/> NTS-450-148 <input type="checkbox"/>		NTS-450-212 <input type="checkbox"/> NTS-450-224 <input type="checkbox"/> NTS-450-248 <input type="checkbox"/>					
		<input type="checkbox"/> = US, GFCI, UN		<input type="checkbox"/> = EU, CN, AU, UK, UN					
OUTPUT	RATED POWER(Continuous)	450W							
	OVER RATED POWER(3 Min.)	517.5W							
	PEAK POWER(10 Sec.)	675W							
	SURGE POWER(30 Cycles)	900W							
	AC VOLTAGE	Default setting set at 110VAC		Default setting set at 230VAC					
	FREQUENCY	100 / 110 / 115 / 120Vac selectable by DIP S.W		200 / 220 / 230 / 240Vac selectable by DIP S.W					
	WAVEFORM	Note.1 True sine wave (THD<3%)							
AC REGULATION	±3.0% at rated input voltage								
FRONT PANEL LED	Please refer to section 3.4 of installation manual								
INPUT	BAT. VOLTAGE	12V	24V	48V	12V	24V	48V		
	VOLTAGE RANGE (Typ.)	10 ~ 16.5Vdc	20 ~ 33Vdc	40 ~ 66Vdc	10 ~ 16.5Vdc	20 ~ 33Vdc	40 ~ 66Vdc		
	DC CURRENT (Typ.)	50A	25A	14A	50A	25A	14A		
	NO LOAD	10W	10W	12W	10W	10W	12W		
	DISSIPATION (Typ.)	NON-SAVING MODE	Default disable, ≤1.2W ~ 1.5W by models @ auto detec AC output load ≤10W will be changed to saving mode						
		SAVING MODE	1.2W	1.3W	1.5W	1.2W	1.3W	1.5W	
	OFF MODE CURRENT DRAW	≤1mA							
	EFFICIENCY (Typ.)	Note.1	88%	91%	91%	90%	93%	93%	
BATTERY TYPES	Lead Acid or li-ion								
PROTECTION	DC INPUT	FUSE (INTERNAL)	40A*2	40A*1	10A*2	40A*2	40A*1	10A*2	
		LOW	ALARM	11±0.3Vdc	22±0.5Vdc	44±1Vdc	11±0.3Vdc	22±0.5Vdc	44±1Vdc
			SHUTDOWN	10±0.3Vdc	20±0.5Vdc	40±1Vdc	10±0.3Vdc	20±0.5Vdc	40±1Vdc
			RESTART	12.5±0.3Vdc	25±0.5Vdc	50±1Vdc	12.5±0.3Vdc	25±0.5Vdc	50±1Vdc
		HIGH	ALARM	15.5±0.3Vdc	31±0.5Vdc	62±1Vdc	15.5±0.3Vdc	31±0.5Vdc	62±1Vdc
			SHUTDOWN	16.5±0.3Vdc	33±0.5Vdc	66±1Vdc	16.5±0.3Vdc	33±0.5Vdc	66±1Vdc
	RESTART		15±0.3Vdc	30±0.5Vdc	60±1Vdc	15±0.3Vdc	30±0.5Vdc	60±1Vdc	
	BAT. POLARITY	By internal fuse open							
	AC OUTPUT	OVER TEMPERATURE	Protection type : Shut down o/p voltage, re-power on to recover						
		OUTPUT SHORT	Protection type : Shut down o/p voltage, re-power on to recover						
		OVER LOAD (Typ.)	105 ~ 115% load for 180 sec., 115% ~ 150% load for 10 sec. Protection type : Shut down o/p voltage, re-power on to recover						
		GFCI PROTECTION	Design refer to UL458 (Only for "GFCI" AC socket, by request)		None				
FUNCTION		REMOTE CONTROL DRY CONTACT	Power ON-OFF remote control by front panel dry contact connector (by RELAY) Open : Normal work ; Short : Remote off						
ENVIRON-MENT	WORK TEMP.	-25 ~ +70°C (Refer to "Derating curve")							
	WORKING HUMIDITY	20 ~ 90% RH non-condensing							
	STORAGE TEMP., HUMIDITY	-30 ~ +70°C / -22 ~ +158°F, 10 ~ 95% RH non-condensing							
	VIBRATION	10 ~ 500Hz, 3G 10min./1cycle, 60min. each along X, Y, Z axes							
OTHER	MTBF	281.3K hrs min. Telcordia TR/SR-332 (Bellcore); 85K hrs min. MIL-HDBK-217F (25°C)							
	DIMENSION	210*130*55mm (L*W*H)							
	PACKING	1.3Kg; 8pcs/ 11.4Kg/ 1.74CUFT							

NTS-750系列

MODEL		NTS-750-112 <input type="checkbox"/> NTS-750-124 <input type="checkbox"/> NTS-750-148 <input type="checkbox"/> NTS-750-212 <input type="checkbox"/> NTS-750-224 <input type="checkbox"/> NTS-750-248 <input type="checkbox"/>							
		<input type="checkbox"/> = US, GFCI, UN			<input type="checkbox"/> = EU, CN, AU, UK, UN				
OUTPUT	RATED POWER(Continuous)	750W							
	OVER RATED POWER(3 Min.)	862.5W							
	PEAK POWER(10 Sec.)	1125W							
	SURGE POWER(30 Cycles)	1500W							
	AC VOLTAGE	Default setting set at 110VAC			Default setting set at 230VAC				
		100 / 110 / 115 / 120Vac selectable by DIP S.W			200 / 220 / 230 / 240Vac selectable by DIP S.W				
	FREQUENCY	Default setting set at 60±0.1Hz			Default setting set at 50Hz±0.1Hz				
		50/60Hz selectable by DIP S.W			50/60Hz selectable by DIP S.W				
WAVEFORM	Note.1 True sine wave (THD<3%)								
AC REGULATION	±3.0% at rated input voltage								
FRONT PANEL LED	Please refer to section 3.4 of installation manual								
INPUT	BAT. VOLTAGE	12V	24V	48V	12V	24V	48V		
	VOLTAGE RANGE (Typ.)	10 ~ 16.5Vdc	20 ~ 33Vdc	40 ~ 66Vdc	10 ~ 16.5Vdc	20 ~ 33Vdc	40 ~ 66Vdc		
	DC CURRENT (Typ.)	75A	38A	19A	75A	38A	19A		
	NO LOAD	10W	10W	12W	10W	10W	12W		
	DISSIPATION (Typ.)	NON-SAVING MODE	Default disable, ≤1.2W ~ 1.5W by models @ auto detec AC output load ≤10W will be changed to saving mode						
		SAVING MODE	1.2W	1.4W	1.5W	1.2W	1.4W	1.5W	
	OFF MODE CURRENT DRAW	≤1mA							
	EFFICIENCY (Typ.)	Note.1 89%		90%	91%	91%	93%	93%	
BATTERY TYPES	Lead Acid or li-ion								
PROTECTION	DC INPUT	FUSE (INTERNAL)	40A*3	40A*2	25A*2	40A*3	40A*2	25A*2	
		LOW	ALARM	11±0.3Vdc	22±0.5Vdc	44±1Vdc	11±0.3Vdc	22±0.5Vdc	44±1Vdc
			SHUTDOWN	10±0.3Vdc	20±0.5Vdc	40±1Vdc	10±0.3Vdc	20±0.5Vdc	40±1Vdc
			RESTART	12.5±0.3Vdc	25±0.5Vdc	50±1Vdc	12.5±0.3Vdc	25±0.5Vdc	50±1Vdc
		HIGH	ALARM	15.5±0.3Vdc	31±0.5Vdc	62±1Vdc	15.5±0.3Vdc	31±0.5Vdc	62±1Vdc
			SHUTDOWN	16.5±0.3Vdc	33±0.5Vdc	66±1Vdc	16.5±0.3Vdc	33±0.5Vdc	66±1Vdc
	RESTART		15±0.3Vdc	30±0.5Vdc	60±1Vdc	15±0.3Vdc	30±0.5Vdc	60±1Vdc	
	BAT. POLARITY	By internal fuse open							
	AC OUTPUT	OVER TEMPERATURE	Protection type : Shut down o/p voltage, re-power on to recover						
		OUTPUT SHORT	Protection type : Shut down o/p voltage, re-power on to recover						
		OVER LOAD (Typ.)	105 ~ 115% load for 180 sec., 115% ~ 150% load for 10 sec. Protection type : Shut down o/p voltage, re-power on to recover						
		GFCI PROTECTION	UL458 (Only for "GFCI" AC socket , by request)			None			
FUNCTION	REMOTE CONTROL	CONNECTOR	Power ON-OFF remote control by front panel dry contact connector (by RELAY) Open : Normal work ; Short : Remote off						
		ACCESSORY	Remote controller sold separately, Order No.: IRC1,IRC2,IRC3						
	RS-232 COMMUNICATION	RS-232 ~ RJ11 Type connector							
ENVIRON- MENT	WORK TEMP.	-25 ~ +70°C (Refer to "Derating curve")							
	WORKING HUMIDITY	20 ~ 90% RH non-condensing							
	STORAGE TEMP., HUMIDITY	-30 ~ +70°C / -22 ~ +158°F, 10 ~ 95% RH non-condensing							
	VIBRATION	10 ~ 500Hz, 3G 10min./1cycle, 60min. each along X, Y, Z axes							
OTHER	MTBF	238.6K hrs min. Telcordia TR/SR-332 (Bellcore); 78K hrs min. MIL-HDBK-217F (25°C)							
	DIMENSION	270*158*67mm (L*W*H)							
	PACKING	2.3Kg; 4pcs/ 10.2Kg/ 1.77CUFT							

NTS-1200系列

MODEL		NTS-1200-112 <input type="checkbox"/> NTS-1200-124 <input type="checkbox"/> NTS-1200-148 <input type="checkbox"/> NTS-1200-212 <input type="checkbox"/> NTS-1200-224 <input type="checkbox"/> NTS-1200-248 <input type="checkbox"/>							
		<input type="checkbox"/> = US, GFCI, UN			<input type="checkbox"/> = EU, CN, AU, UK, UN				
OUTPUT	RATED POWER(Continuous)	1200W							
	OVER RATED POWER(3 Min.)	1380W							
	PEAK POWER(10 Sec.)	1800W							
	SURGE POWER(30 Cycles)	2000W							
	AC VOLTAGE	Default setting set at 110VAC			Default setting set at 230VAC				
		100 / 110 / 115 / 120Vac selectable by DIP S.W			200 / 220 / 230 / 240Vac selectable by DIP S.W				
	FREQUENCY	Default setting set at 60±0.1Hz			Default setting set at 50Hz±0.1Hz				
		50/60Hz selectable by DIP S.W			50/60Hz selectable by DIP S.W				
WAVEFORM	Note.1 True sine wave (THD<3%)								
AC REGULATION	±3.0% at rated input voltage								
FRONT PANEL LED	Please refer to section 3.4 of installation manual								
INPUT	BAT. VOLTAGE	12V	24V	48V	12V	24V	48V		
	VOLTAGE RANGE (Typ.)	10 ~ 16.5Vdc	20 ~ 33Vdc	40 ~ 66Vdc	10 ~ 16.5Vdc	20 ~ 33Vdc	40 ~ 66Vdc		
	DC CURRENT (Typ.)	120A	60A	30A	120A	60A	30A		
	NO LOAD	15W	25W						
	DISSIPATION (Typ.)	NON-SAVING MODE	Default disable, auto detec AC output load ≤10W will be changed to saving mode						
		SAVING MODE	1.2W	1.4W	1.5W	1.2W	1.4W	1.5W	
	OFF MODE CURRENT DRAW	≤1mA							
	EFFICIENCY (Typ.)	Note.1 89%		90%	91%	90%	92%	93%	
BATTERY TYPES	Lead Acid or li-ion								
PROTECTION	DC INPUT	FUSE (INTERNAL)	40A*4	40A*2	25A*2	40A*4	40A*2	25A*2	
		LOW	ALARM	11±0.3Vdc	22±0.5Vdc	44±1Vdc	11±0.3Vdc	22±0.5Vdc	44±1Vdc
			SHUTDOWN	10±0.3Vdc	20±0.5Vdc	40±1Vdc	10±0.3Vdc	20±0.5Vdc	40±1Vdc
			RESTART	12.5±0.3Vdc	25±0.5Vdc	50±1Vdc	12.5±0.3Vdc	25±0.5Vdc	50±1Vdc
		HIGH	ALARM	15.5±0.3Vdc	31±0.5Vdc	62±1Vdc	15.5±0.3Vdc	31±0.5Vdc	62±1Vdc
			SHUTDOWN	16.5±0.3Vdc	33±0.5Vdc	66±1Vdc	16.5±0.3Vdc	33±0.5Vdc	66±1Vdc
	RESTART		15±0.3Vdc	30±0.5Vdc	60±1Vdc	15±0.3Vdc	30±0.5Vdc	60±1Vdc	
	BAT. POLARITY	By internal fuse open							
	AC OUTPUT	OVER TEMPERATURE	Protection type : Shut down o/p voltage, re-power on to recover						
		OUTPUT SHORT	Protection type : Shut down o/p voltage, re-power on to recover						
		OVER LOAD (Typ.)	105 ~ 115% load for 180 sec., 115% ~ 150% load for 10 sec. Protection type : Shut down o/p voltage, re-power on to recover						
		GFCI PROTECTION	UL458 (Only for "GFCI" AC socket)			None			
FUNCTION	REMOTE CONTROL	CONNECTOR	Power ON-OFF remote control by front panel dry contact connector (by RELAY) Open : Normal work ; Short : Remote off						
		ACCESSORY	Remote controller sold separately, Order No.: IRC1,IRC2,IRC3						
	RS-232 COMMUNICATION	RS-232 ~ RJ11 Type connector							
ENVIRON- MENT	WORK TEMP.	-25 ~ +70°C (Refer to "Derating curve")							
	WORKING HUMIDITY	20 ~ 90% RH non-condensing							
	STORAGE TEMP., HUMIDITY	-30 ~ +70°C / -22 ~ +158°F, 10 ~ 95% RH non-condensing							
	VIBRATION	10 ~ 500Hz, 3G 10min./1cycle, 60min. each along X, Y, Z axes							
OTHER	MTBF	198.9K hrs min. Telcordia TR/SR-332 (Bellcore); 62.0K hrs min. MIL-HDBK-217F (25°C)							
	DIMENSION	333*184*70mm (L*W*H)							
	PACKING	3.3Kg; 2pcs/ 7.6Kg/ 1.16CUFT							

NTS-1700系列

MODEL		NTS-1700-112 <input type="checkbox"/> NTS-1700-124 <input type="checkbox"/> NTS-1700-148 <input type="checkbox"/>			NTS-1700-212 <input type="checkbox"/> NTS-1700-224 <input type="checkbox"/> NTS-1700-248 <input type="checkbox"/>				
		<input type="checkbox"/> = US, GFCI, UN			<input type="checkbox"/> = EU, CN, AU, UK, UN				
OUTPUT	RATED POWER(Continuous)	1500W			1700W				
	OVER RATED POWER(3 Min.)	1750W			2000W				
	PEAK POWER(10 Sec.)	2250W			2550W				
	SURGE POWER(30 Cycles)	3000W			3400W				
	AC VOLTAGE	Default setting set at 110VAC 100 / 110 / 115 / 120Vac selectable by DIP S.W			Default setting set at 230VAC 200 / 220 / 230 / 240Vac selectable by DIP S.W				
	FREQUENCY	Default setting set at 60±0.1Hz 50/60Hz selectable by DIP S.W			Default setting set at 50Hz±0.1Hz 50/60Hz selectable by DIP S.W				
	WAVEFORM	Note.1 True sine wave (THD<3%)							
	AC REGULATION	±3.0% at rated input voltage							
FRONT PANEL LED Please refer to section 3.4 of installation manual									
INPUT	BAT. VOLTAGE	12V	24V	48V	12V	24V	48V		
	VOLTAGE RANGE (Typ.)	10 ~ 16.5Vdc	20 ~ 33Vdc	40 ~ 66Vdc	10 ~ 16.5Vdc	20 ~ 33Vdc	40 ~ 66Vdc		
	DC CURRENT (Typ.)	150A	75A	37.5A	170A	85A	42.5A		
	NO LOAD DISSIPATION (Typ.)	Default disable, ≤ 1.2W ~ 1.5W by models @ auto detect AC output load ≤ 10W will be changed to saving mode							
	SAVING MODE (Typ.)	1.2W	1.4W	1.5W	1.2W	1.4W	1.5W		
	OFF MODE CURRENT DRAW	≤ 1mA							
	EFFICIENCY (Typ.)	Note.1 89%		90%	91%	90%	92%	93%	
	BATTERY TYPES	Lead Acid or li-ion							
PROTECTION	DC INPUT	FUSE (INTERNAL)	40A*5	30A*3	30A*2	40A*5	30A*3	30A*2	
		LOW	ALARM	11±0.3Vdc	22±0.5Vdc	44±1Vdc	11±0.3Vdc	22±0.5Vdc	44±1Vdc
			SHUTDOWN	10±0.3Vdc	20±0.5Vdc	40±1Vdc	10±0.3Vdc	20±0.5Vdc	40±1Vdc
			RESTART	12.5±0.3Vdc	25±0.5Vdc	50±1Vdc	12.5±0.3Vdc	25±0.5Vdc	50±1Vdc
		HIGH	ALARM	15.5±0.3Vdc	31±0.5Vdc	62±1Vdc	15.5±0.3Vdc	31±0.5Vdc	62±1Vdc
			SHUTDOWN	16.5±0.3Vdc	33±0.5Vdc	66±1Vdc	16.5±0.3Vdc	33±0.5Vdc	66±1Vdc
	RESTART		15±0.3Vdc	30±0.5Vdc	60±1Vdc	15±0.3Vdc	30±0.5Vdc	60±1Vdc	
	BAT. POLARITY		By internal fuse open						
	OVER TEMPERATURE		Protection type : Shut down o/p voltage, re-power on to recover						
	OUTPUT SHORT		Protection type : Shut down o/p voltage, re-power on to recover						
	OVER LOAD (Typ.)		105 ~ 115% load for 180 sec., 115% ~ 150% load for 10 sec. Protection type : Shut down o/p voltage, re-power on to recover						
	CIRCUIT BREAKER(GFCI)		15A			10A			
GFCI PROTECTION		UL458 (Only for "GFCI" AC socket) None							
FUNCTION	REMOTE CONTROL	CONNECTOR	Power ON-OFF remote control by front panel dry contact connector (by RELAY) Open : Normal work ; Short : Remote off						
		ACCESSORY	Remote controller sold separately, Order No.: IRC1,IRC2,IRC3						
	RS-232 COMMUNICATION	RS-232 ~ RJ11 Type connector							
ENVIRON-MENT	WORK TEMP.	-20 ~ +70°C (Refer to "Derating curve")							
	WORKING HUMIDITY	20 ~ 90% RH non-condensing							
	STORAGE TEMP., HUMIDITY	-30 ~ +70°C / -22 ~ +158°F, 10 ~ 95% RH non-condensing							
	VIBRATION	10 ~ 500Hz, 3G 10min./1cycle, 60min. each along X, Y, Z axes							
OTHER	MTBF	475.5K hrs min. Telcordia TR/SR-332 (Bellcore);		46.2K hrs min. MIL-HDBK-217F (25°C)					
	DIMENSION	400*184*70mm (L*W*H)							
	PACKING	4.63Kg; 2pcs/ 12Kg/ 1.76CUFT							

NTS-2200系列

MODEL		NTS-2200-112 <input type="checkbox"/> NTS-2200-124 <input type="checkbox"/> NTS-2200-148 <input type="checkbox"/>			NTS-2200-212 <input type="checkbox"/> NTS-2200-224 <input type="checkbox"/> NTS-2200-248 <input type="checkbox"/>				
		<input type="checkbox"/> = US, UN, TB			<input type="checkbox"/> = EU, CN, AU, UK, UN, TB				
OUTPUT	RATED POWER(Continuous)	2200W							
	OVER RATED POWER(3 Min.)	2530W							
	PEAK POWER(10 Sec.)	3300W							
	SURGE POWER(30 Cycles)	4400W							
	AC VOLTAGE	Default setting set at 110VAC 100 / 110 / 115 / 120Vac selectable by DIP S.W			Default setting set at 230VAC 200 / 220 / 230 / 240Vac selectable by DIP S.W				
	FREQUENCY	Default setting set at 60±0.1Hz 50/60Hz selectable by DIP S.W			Default setting set at 50Hz±0.1Hz 50/60Hz selectable by DIP S.W				
	WAVEFORM	Note.1 True sine wave (THD<3%)							
	AC REGULATION	±3.0% at rated input voltage							
FRONT PANEL LED Please refer to section 3.4 of installation manual									
INPUT	BAT. VOLTAGE	12V	24V	48V	12V	24V	48V		
	VOLTAGE RANGE (Typ.)	10 ~ 16.5Vdc	20 ~ 33Vdc	40 ~ 66Vdc	10 ~ 16.5Vdc	20 ~ 33Vdc	40 ~ 66Vdc		
	DC CURRENT (Typ.)	250A	120A	60A	250A	120A	60A		
	NO LOAD DISSIPATION (Typ.)	Default disable, auto detec AC output load ≤ 10W will be changed to saving mode							
	SAVING MODE (Typ.)	1.7W							
	OFF MODE CURRENT DRAW	≤ 2mA							
	EFFICIENCY (Typ.)	Note.1 89%		90%	91%	90%	92%	93%	
	BATTERY TYPES	Lead Acid or li-ion							
PROTECTION	DC INPUT	FUSE (INTERNAL)	40A*8	40A*4	25A*4	40A*8	40A*4	25A*4	
		LOW	ALARM	11±0.3Vdc	22±0.5Vdc	44±1Vdc	11±0.3Vdc	22±0.5Vdc	44±1Vdc
			SHUTDOWN	10±0.3Vdc	20±0.5Vdc	40±1Vdc	10±0.3Vdc	20±0.5Vdc	40±1Vdc
			RESTART	12.5±0.3Vdc	25±0.5Vdc	50±1Vdc	12.5±0.3Vdc	25±0.5Vdc	50±1Vdc
		HIGH	ALARM	15.5±0.3Vdc	31±0.5Vdc	62±1Vdc	15.5±0.3Vdc	31±0.5Vdc	62±1Vdc
			SHUTDOWN	16.5±0.3Vdc	33±0.5Vdc	66±1Vdc	16.5±0.3Vdc	33±0.5Vdc	66±1Vdc
	RESTART		15±0.3Vdc	30±0.5Vdc	60±1Vdc	15±0.3Vdc	30±0.5Vdc	60±1Vdc	
	BAT. POLARITY		By internal fuse open						
	OVER TEMPERATURE		Protection type : Shut down o/p voltage, re-power on to recover						
	OUTPUT SHORT		Protection type : Shut down o/p voltage, re-power on to recover						
	OVER LOAD (Typ.)		105 ~ 115% load for 180 sec., 115% ~ 150% load for 10 sec. Protection type : Shut down o/p voltage, re-power on to recover						
	CIRCUIT BREAKER		25A (Only for "TB" AC socket)			None			
TB TYPE		UL458 (Only for "TB" AC socket)			None				
FUNCTION	REMOTE CONTROL	CONNECTOR	Power ON-OFF remote control by front panel dry contact connector (by RELAY) Open : Normal work ; Short : Remote off						
		ACCESSORY	Remote controller sold separately, Order No.: IRC1,IRC2,IRC3						
	RS-232 COMMUNICATION	RS-232 ~ RJ11 Type connector							
ENVIRON-MENT	WORK TEMP.	-25 ~ +70°C (Refer to "Derating curve")							
	WORKING HUMIDITY	20 ~ 90% RH non-condensing							
	STORAGE TEMP., HUMIDITY	-30 ~ +70°C / -22 ~ +158°F, 10 ~ 95% RH non-condensing							
	VIBRATION	10 ~ 500Hz, 3G 10min./1cycle, 60min. each along X, Y, Z axes							
OTHER	MTBF	364.7K hrs min. Telcordia TR/SR-332 (Bellcore);		34.9K hrs min. MIL-HDBK-217F (25°C)					
	DIMENSION	420*270*98mm (L*W*H)							
	PACKING	8.6Kg; 1pcs/ 10.4Kg/ 1.39CUFT							

NTS-3200系列

MODEL		NTS-3200-112 <input type="checkbox"/> NTS-3200-124 <input type="checkbox"/> NTS-3200-148 <input type="checkbox"/>			NTS-3200-212 <input type="checkbox"/> NTS-3200-224 <input type="checkbox"/> NTS-3200-248 <input type="checkbox"/>				
		<input type="checkbox"/> = US, UN, TB			<input type="checkbox"/> = EU, CN, AU, UK, UN, TB				
OUTPUT	RATED POWER(Continuous)	3200W			3200W				
	OVER RATED POWER(3 Min.)	3500W			3680W				
	PEAK POWER(10 Sec.)	4500W			4800W				
	SURGE POWER(30 Cycles)	6000W			6400W				
	AC VOLTAGE	Default setting set at 110VAC 100 / 110 / 115 / 120Vac selectable by DIP S.W			Default setting set at 230VAC 200 / 220 / 230 / 240Vac selectable by DIP S.W				
	FREQUENCY	Default setting set at 60±0.1Hz 50/60Hz selectable by DIP S.W			Default setting set at 50Hz±0.1Hz 50/60Hz selectable by DIP S.W				
	WAVEFORM	Note.1 True sine wave (THD<3%)							
	AC REGULATION	±3.0% at rated input voltage							
FRONT PANEL LED Please refer to section 3.4 of installation manual									
INPUT	BAT. VOLTAGE	12V	24V	48V	12V	24V	48V		
	VOLTAGE RANGE (Typ.)	10 ~ 16.5Vdc	20 ~ 33Vdc	40 ~ 66Vdc	10 ~ 16.5Vdc	20 ~ 33Vdc	40 ~ 66Vdc		
	DC CURRENT (Typ.)	300A	150A	75A	320A	160A	80A		
	NO LOAD DISSIPATION (Typ.)	Default disable, auto detec AC output load ≤10W will be changed to saving mode							
	SAVING MODE	1.7W							
	OFF MODE CURRENT DRAW	≤2mA							
	EFFICIENCY (Typ.)	Note.1 89%	90%	91%	90%	92%	93%		
	BATTERY TYPES	Lead Acid or li-ion							
PROTECTION	DC INPUT	FUSE (INTERNAL)	40A*12	40A*6	25A*6	40A*12	40A*6	25A*6	
		LOW	ALARM	11±0.3Vdc	22±0.5Vdc	44±1Vdc	11±0.3Vdc	22±0.5Vdc	44±1Vdc
			SHUTDOWN	10±0.3Vdc	20±0.5Vdc	40±1Vdc	10±0.3Vdc	20±0.5Vdc	40±1Vdc
			RESTART	12.5±0.3Vdc	25±0.5Vdc	50±1Vdc	12.5±0.3Vdc	25±0.5Vdc	50±1Vdc
		HIGH	ALARM	15.5±0.3Vdc	31±0.5Vdc	62±1Vdc	15.5±0.3Vdc	31±0.5Vdc	62±1Vdc
			SHUTDOWN	16.5±0.3Vdc	33±0.5Vdc	66±1Vdc	16.5±0.3Vdc	33±0.5Vdc	66±1Vdc
	RESTART		15±0.3Vdc	30±0.5Vdc	60±1Vdc	15±0.3Vdc	30±0.5Vdc	60±1Vdc	
	BAT. POLARITY	By internal fuse open							
	AC OUTPUT	OVER TEMPERATURE	Protection type : Shut down o/p voltage, re-power on to recover						
		OUTPUT SHORT	Protection type : Shut down o/p voltage, re-power on to recover						
		OVER LOAD (Typ.)	105 ~ 115% load for 180 sec., 115% ~ 150% load for 10 sec. Protection type : Shut down o/p voltage, re-power on to recover						
		CIRCUIT BREAKER	30A (Only for "TB" AC socket)			None			
TB TYPE		UL458 (Only for "TB" AC socket)			None				
FUNCTION		REMOTE CONTROL	Power ON-OFF remote control by front panel dry contact connector (by RELAY) Open : Normal work ; Short : Remote off						
	CONNECTOR	Remote controller sold separately, Order No.: IRC1,IRC2,IRC3							
	ACCESSORY	Remote controller sold separately, Order No.: IRC1,IRC2,IRC3							
RS-232 COMMUNICATION	RS-232 ~ RJ11 Type connector								
ENVIRON- MENT	WORK TEMP.	-25 ~ +70°C (Refer to "Derating curve")							
	WORKING HUMIDITY	20 ~ 90% RH non-condensing							
	STORAGE TEMP., HUMIDITY	-30 ~ +70°C / -22 ~ +158°F, 10 ~ 95% RH non-condensing							
	VIBRATION	10 ~ 500Hz, 3G 10min./1cycle, 60min. each along X, Y, Z axes							
OTHER	MTBF	336.9K hrs min. Telcordia TR/SR-332 (Bellcore); 30.5K hrs min. MIL-HDBK-217F (25°C)							
	DIMENSION	420*270*98mm (L*W*H)							
	PACKING	8.6Kg; 1pcs/ 10.4Kg/ 1.39CUFT							

NTU-1200系列(内建UPS功能)

MODEL		NTU-1200-112 <input type="checkbox"/> NTU-1200-124 <input type="checkbox"/> NTU-1200-148 <input type="checkbox"/>			NTU-1200-212 <input type="checkbox"/> NTU-1200-224 <input type="checkbox"/> NTU-1200-248 <input type="checkbox"/>				
		<input type="checkbox"/> = US, GFCI, UN			<input type="checkbox"/> = EU, CN, AU, UK, UN				
OUTPUT	RATED POWER(Continuous)	1200W							
	OVER RATED POWER(3 Min.)	1380W							
	PEAK POWER(10 Sec.)	1800W							
	SURGE POWER(30 Cycles)	2000W							
	AC VOLTAGE	Default setting set at 110VAC 100 / 110 / 115 / 120Vac selectable by DIP S.W			Default setting set at 230VAC 200 / 220 / 230 / 240Vac selectable by DIP S.W				
	FREQUENCY	Default setting set at 60±0.1Hz 50/60Hz selectable by DIP S.W			Default setting set at 50Hz±0.1Hz 50/60Hz selectable by DIP S.W				
	WAVEFORM	Note.1 True sine wave (THD<3%)							
	AC REGULATION	±3.0% at rated input voltage							
FRONT PANEL LED Please refer to section 3.4 of installation manual									
INPUT	BAT. VOLTAGE	12V	24V	48V	12V	24V	48V		
	VOLTAGE RANGE (Typ.)	10 ~ 16.5Vdc	20 ~ 33Vdc	40 ~ 66Vdc	10 ~ 16.5Vdc	20 ~ 33Vdc	40 ~ 66Vdc		
	DC CURRENT (Typ.)	120A	60A	30A	120A	60A	30A		
	NO LOAD DISSIPATION (Typ.)	15W			25W				
	SAVING MODE	Default disable, auto detec AC output load ≤10W will be changed to saving mode							
	OFF MODE CURRENT DRAW	≤1mA							
	EFFICIENCY (Typ.)	Note.1 89%	90%	91%	90%	92%	93%		
	BATTERY TYPES	Lead Acid or li-ion							
PROTECTION	DC INPUT	FUSE (INTERNAL)	40A*4	40A*2	25A*2	40A*4	40A*2	25A*2	
		LOW	ALARM	11±0.3Vdc	22±0.5Vdc	44±1Vdc	11±0.3Vdc	22±0.5Vdc	44±1Vdc
			SHUTDOWN	10±0.3Vdc	20±0.5Vdc	40±1Vdc	10±0.3Vdc	20±0.5Vdc	40±1Vdc
			RESTART	12.5±0.3Vdc	25±0.5Vdc	50±1Vdc	12.5±0.3Vdc	25±0.5Vdc	50±1Vdc
		HIGH	ALARM	15.5±0.3Vdc	31±0.5Vdc	62±1Vdc	15.5±0.3Vdc	31±0.5Vdc	62±1Vdc
			SHUTDOWN	16.5±0.3Vdc	33±0.5Vdc	66±1Vdc	16.5±0.3Vdc	33±0.5Vdc	66±1Vdc
	RESTART		15±0.3Vdc	30±0.5Vdc	60±1Vdc	15±0.3Vdc	30±0.5Vdc	60±1Vdc	
	BAT. POLARITY	By internal fuse open							
	AC OUTPUT	OVER TEMPERATURE	Protection type : Shut down o/p voltage, re-power on to recover						
		OUTPUT SHORT	Protection type : Shut down o/p voltage, re-power on to recover						
		OVER LOAD (Typ.)	105 ~ 115% load for 180 sec., 115% ~ 150% load for 10 sec. Protection type : Shut down o/p voltage, re-power on to recover						
		CIRCUIT BREAKER	15A			10A			
GFCI PROTECTION		UL458 (Only for "GFCI" AC socket)			None				
FUNCTION		REMOTE CONTROL	Power ON-OFF remote control by front panel dry contact connector (by RELAY) Open : Normal work ; Short : Remote off						
	CONNECTOR	Remote controller sold separately, Order No.: IRC1,IRC2,IRC3							
	ACCESSORY	Remote controller sold separately, Order No.: IRC1,IRC2,IRC3							
RS-232 COMMUNICATION	RS-232 ~ RJ11 Type connector								
AC UPS MODE	AC INPUT RANGE	100/110/115/120Vac ±16%, recover ±13%			200/220/230/240Vac ±16%, recover ±13%				
	FREQUENCY RANGE	45 ~ 65Hz							
	TRANSFER TIME (Typ.)	10ms inverter → AC by pass							
ENVIRON- MENT	WORK TEMP.	-25 ~ +70°C (Refer to "Derating curve")							
	WORKING HUMIDITY	20 ~ 90% RH non-condensing							
	STORAGE TEMP., HUMIDITY	-30 ~ +70°C / -22 ~ +158°F, 10 ~ 95% RH non-condensing							
	VIBRATION	10 ~ 500Hz, 3G 10min./1cycle, 60min. each along X, Y, Z axes							
OTHER	MTBF	166.3K hrs min. Telcordia TR/SR-332 (Bellcore); 58.3K hrs min. MIL-HDBK-217F (25°C)							
	DIMENSION	333*184*70mm (L*W*H)							
	PACKING	3.3Kg; 2pcs/ 7.6Kg/ 1.16CUFT							

NTU-1700系列(內建UPS功能)

MODEL		NTU-1700-112 <input type="checkbox"/> NTU-1700-124 <input type="checkbox"/> NTU-1700-148 <input type="checkbox"/>			NTU-1700-212 <input type="checkbox"/> NTU-1700-224 <input type="checkbox"/> NTU-1700-248 <input type="checkbox"/>				
		<input type="checkbox"/> = US, GFCI, UN			<input type="checkbox"/> = EU, CN, AU, UK, UN				
OUTPUT	RATED POWER(Continuous)	1500W			1700W				
	OVER RATED POWER(3 Min.)	1750W			2000W				
	PEAK POWER(10 Sec.)	2250W			2550W				
	SURGE POWER(30 Cycles)	3000W			3400W				
	AC VOLTAGE	Default setting set at 110VAC 100 / 110 / 115 / 120Vac selectable by DIP S.W			Default setting set at 230VAC 200 / 220 / 230 / 240Vac selectable by DIP S.W				
	FREQUENCY	Default setting set at 60±0.1Hz 50/60Hz selectable by DIP S.W			Default setting set at 50Hz±0.1Hz 50/60Hz selectable by DIP S.W				
	WAVEFORM	Note.1 True sine wave (THD<3%)							
	AC REGULATION	±3.0% at rated input voltage							
FRONT PANEL LED Please refer to section 3.4 of installation manual									
INPUT	BAT. VOLTAGE	12V	24V	48V	12V	24V	48V		
	VOLTAGE RANGE (Typ.)	10 ~ 16.5Vdc	20 ~ 33Vdc	40 ~ 66Vdc	10 ~ 16.5Vdc	20 ~ 33Vdc	40 ~ 66Vdc		
	DC CURRENT (Typ.)	150A	75A	37.5A	170A	85A	42.5A		
	POWER SAVING MODE	≤1.2W@standby saving, mode when AC output load ≤10W, auto wake up when AC output load ≥15W							
	OFF MODE CURRENT DRAW	≤1mA							
	EFFICIENCY (Typ.)	Note.1 89%		90%	91%	90%	92%	93%	
	BATTERY TYPES Lead Acid or li-ion								
PROTECTION	DC INPUT	FUSE (INTERNAL)		40A*5	30A*3	30A*2	40A*5	30A*3	30A*2
		LOW	ALARM	11±0.3Vdc	22±0.5Vdc	44±1Vdc	11±0.3Vdc	22±0.5Vdc	44±1Vdc
			SHUTDOWN	10±0.3Vdc	20±0.5Vdc	40±1Vdc	10±0.3Vdc	20±0.5Vdc	40±1Vdc
			RESTART	12.5±0.3Vdc	25±0.5Vdc	50±1Vdc	12.5±0.3Vdc	25±0.5Vdc	50±1Vdc
		HIGH	ALARM	15.5±0.3Vdc	31±0.5Vdc	62±1Vdc	15.5±0.3Vdc	31±0.5Vdc	62±1Vdc
			SHUTDOWN	16.5±0.3Vdc	33±0.5Vdc	66±1Vdc	16.5±0.3Vdc	33±0.5Vdc	66±1Vdc
	RESTART		15±0.3Vdc	30±0.5Vdc	60±1Vdc	15±0.3Vdc	30±0.5Vdc	60±1Vdc	
	BAT. POLARITY		By internal fuse open						
	AC OUTPUT	OVER TEMPERATURE		Protection type : Shut down o/p voltage, re-power on to recover					
		OUTPUT SHORT		Protection type : Shut down o/p voltage, re-power on to recover					
		OVER LOAD (Typ.)		105 ~ 115% load for 180 sec., 115% ~ 150% load for 10 sec.					
		CIRCUIT BREAKER(GFCI)		15A			10A		
		GFCI PROTECTION		UL458 (Only for "GFCI" AC socket) None					
	FUNCTION	REMOTE CONTROL	CONNECTOR	Power ON-OFF remote control by front panel dry contact connector (by RELAY) Open : Normal work ; Short : Remote off					
ACCESSORY			Remote controller sold separately, Order No.: IRC1,IRC2,IRC3						
RS-232 COMMUNICATION		RS-232 ~ RJ11 Type connector							
AC UPS MODE	AC INPUT RANGE		100/110/115/120Vac±16%, recover±13%			200/220/230/240Vac±16%, recover±13%			
	FREQUENCY RANGE		45 ~ 65Hz						
	TRANSFER TIME (Typ.)		10ms inverter → AC by pass						
ENVIRON- MENT	WORK TEMP.		-20 ~ +70°C (Refer to "Derating curve")						
	WORKING HUMIDITY		20 ~ 90% RH non-condensing						
	STORAGE TEMP., HUMIDITY		-30 ~ +70°C / -22 ~ +158°F, 10 ~ 95% RH non-condensing						
	VIBRATION		10 ~ 500Hz, 3G 10min./1cycle, 60min. each along X, Y, Z axes						
OTHER	MTBF		421.9K hrs min. Telcordia TR/SR-332 (Bellcore);			45.3K hrs min. MIL-HDBK-217F (25°C)			
	DIMENSION		400*184*70mm (L*W*H)						
	PACKING		4.63Kg; 2pcs/ 12Kg/ 1.76CUFT						

NTU-2200系列(內建UPS功能)

MODEL		NTU-2200-112 <input type="checkbox"/> NTU-2200-124 <input type="checkbox"/> NTU-2200-148 <input type="checkbox"/>			NTU-2200-212 <input type="checkbox"/> NTU-2200-224 <input type="checkbox"/> NTU-2200-248 <input type="checkbox"/>				
		<input type="checkbox"/> = US, UN, TB			<input type="checkbox"/> = EU, CN, AU, UK, UN, TB				
OUTPUT	RATED POWER(Continuous)	2200W							
	OVER RATED POWER(3 Min.)	2530W							
	PEAK POWER(10 Sec.)	3300W							
	SURGE POWER(30 Cycles)	4400W							
	AC VOLTAGE	Default setting set at 110VAC 100 / 110 / 115 / 120Vac selectable by DIP S.W			Default setting set at 230VAC 200 / 220 / 230 / 240Vac selectable by DIP S.W				
	FREQUENCY	Default setting set at 60±0.1Hz 50/60Hz selectable by DIP S.W			Default setting set at 50Hz±0.1Hz 50/60Hz selectable by DIP S.W				
	WAVEFORM	Note.1 True sine wave (THD<3%)							
	AC REGULATION	±3.0% at rated input voltage							
FRONT PANEL LED Please refer to section 3.4 of installation manual									
INPUT	BAT. VOLTAGE	12V	24V	48V	12V	24V	48V		
	VOLTAGE RANGE (Typ.)	10 ~ 16.5Vdc	20 ~ 33Vdc	40 ~ 66Vdc	10 ~ 16.5Vdc	20 ~ 33Vdc	40 ~ 66Vdc		
	DC CURRENT (Typ.)	250A	120A	60A	250A	120A	60A		
	NO LOAD DISSIPATION (Typ.)	Default disable, auto detec AC output load ≤10W will be changed to saving mode							
	SAVING MODE	15W							
	OFF MODE CURRENT DRAW	≤2mA							
	EFFICIENCY (Typ.)	Note.1 89%		90%	91%	90%	92%	93%	
BATTERY TYPES Lead Acid or li-ion									
PROTECTION	DC INPUT	FUSE (INTERNAL)		40A*8	40A*4	25A*4	40A*8	40A*4	25A*4
		LOW	ALARM	11±0.3Vdc	22±0.5Vdc	44±1Vdc	11±0.3Vdc	22±0.5Vdc	44±1Vdc
			SHUTDOWN	10±0.3Vdc	20±0.5Vdc	40±1Vdc	10±0.3Vdc	20±0.5Vdc	40±1Vdc
			RESTART	12.5±0.3Vdc	25±0.5Vdc	50±1Vdc	12.5±0.3Vdc	25±0.5Vdc	50±1Vdc
		HIGH	ALARM	15.5±0.3Vdc	31±0.5Vdc	62±1Vdc	15.5±0.3Vdc	31±0.5Vdc	62±1Vdc
			SHUTDOWN	16.5±0.3Vdc	33±0.5Vdc	66±1Vdc	16.5±0.3Vdc	33±0.5Vdc	66±1Vdc
	RESTART		15±0.3Vdc	30±0.5Vdc	60±1Vdc	15±0.3Vdc	30±0.5Vdc	60±1Vdc	
	BAT. POLARITY		By internal fuse open						
	AC OUTPUT	OVER TEMPERATURE		Protection type : Shut down o/p voltage, re-power on to recover					
		OUTPUT SHORT		Protection type : Shut down o/p voltage, re-power on to recover					
		OVER LOAD (Typ.)		105 ~ 115% load for 180 sec., 115% ~ 150% load for 10 sec.					
		CIRCUIT BREAKER		25A			15A		
		TB TYPE		UL458 (Only for "TB" AC socket) None					
	FUNCTION	REMOTE CONTROL	CONNECTOR	Power ON-OFF remote control by front panel dry contact connector (by RELAY) Open : Normal work ; Short : Remote off					
ACCESSORY			Remote controller sold separately, Order No.: IRC1,IRC2,IRC3						
RS-232 COMMUNICATION		RS-232 ~ RJ11 Type connector							
AC UPS MODE	AC INPUT RANGE		100/110/115/120Vac±16%, recover±13%			200/220/230/240Vac±16%, recover±13%			
	FREQUENCY RANGE		45 ~ 65Hz						
	TRANSFER TIME (Typ.)		10ms inverter → AC by pass						
ENVIRON- MENT	WORK TEMP.		-25 ~ +70°C (Refer to "Derating curve")						
	WORKING HUMIDITY		20 ~ 90% RH non-condensing						
	STORAGE TEMP., HUMIDITY		-30 ~ +70°C / -22 ~ +158°F, 10 ~ 95% RH non-condensing						
	VIBRATION		10 ~ 500Hz, 3G 10min./1cycle, 60min. each along X, Y, Z axes						
OTHER	MTBF		344.9K hrs min. Telcordia TR/SR-332 (Bellcore);			34.8K hrs min. MIL-HDBK-217F (25°C)			
	DIMENSION		420*270*98mm (L*W*H)						
	PACKING		8.6Kg; 1pcs/ 10.4Kg/ 1.39CUFT						

NTU-3200系列(內建UPS功能)

MODEL		NTU-3200-112 <input type="checkbox"/> NTU-3200-124 <input type="checkbox"/> NTU-3200-148 <input type="checkbox"/> NTU-3200-212 <input type="checkbox"/> NTU-3200-224 <input type="checkbox"/> NTU-3200-248 <input type="checkbox"/>			<input type="checkbox"/> = US, UN, TB <input type="checkbox"/> <input type="checkbox"/> = EU, CN, AU, UK, UN, TB				
OUTPUT	RATED POWER(Continuous)	3000W			3200W				
	OVER RATED POWER(3 Min.)	3500W			3680W				
	PEAK POWER(10 Sec.)	4500W			4800W				
	SURGE POWER(30 Cycles)	6000W			6400W				
	AC VOLTAGE	Default setting set at 110VAC 100 / 110 / 115 / 120Vac selectable by DIP S.W			Default setting set at 230VAC 200 / 220 / 230 / 240Vac selectable by DIP S.W				
	FREQUENCY	Default setting set at 60±0.1Hz 50/60Hz selectable by DIP S.W			Default setting set at 50Hz±0.1Hz 50/60Hz selectable by DIP S.W				
	WAVEFORM <small>Note.1</small>	True sine wave (THD<3%)							
	AC REGULATION	±3.0% at rated input voltage							
	FRONT PANEL LED	Please refer to section 3.4 of installation manual							
INPUT	BAT. VOLTAGE	12V	24V	48V	12V	24V	48V		
	VOLTAGE RANGE (Typ.)	10 ~ 16.5Vdc	20 ~ 33Vdc	40 ~ 66Vdc	10 ~ 16.5Vdc	20 ~ 33Vdc	40 ~ 66Vdc		
	DC CURRENT (Typ.)	300A	150A	75A	320A	160A	80A		
	NO LOAD DISSIPATION (Typ.)	Default disable, auto detec AC output load ≤10W will be changed to saving mode							
	SAVING MODE (Typ.)	15W							
	OFF MODE CURRENT DRAW	≤2mA							
	EFFICIENCY (Typ.) <small>Note.1</small>	89%	90%	91%	90%	92%	93%		
	BATTERY TYPES	Lead Acid or li-ion							
PROTECTION	DC INPUT	FUSE (INTERNAL)	40A*12	40A*6	25A*6	40A*12	40A*6	25A*6	
		LOW	ALARM	11±0.3Vdc	22±0.5Vdc	44±1Vdc	11±0.3Vdc	22±0.5Vdc	44±1Vdc
			SHUTDOWN	10±0.3Vdc	20±0.5Vdc	40±1Vdc	10±0.3Vdc	20±0.5Vdc	40±1Vdc
			RESTART	12.5±0.3Vdc	25±0.5Vdc	50±1Vdc	12.5±0.3Vdc	25±0.5Vdc	50±1Vdc
		HIGH	ALARM	15.5±0.3Vdc	31±0.5Vdc	62±1Vdc	15.5±0.3Vdc	31±0.5Vdc	62±1Vdc
			SHUTDOWN	16.5±0.3Vdc	33±0.5Vdc	66±1Vdc	16.5±0.3Vdc	33±0.5Vdc	66±1Vdc
			RESTART	15±0.3Vdc	30±0.5Vdc	60±1Vdc	15±0.3Vdc	30±0.5Vdc	60±1Vdc
	AC OUTPUT	BAT. POLARITY	By internal fuse open						
		OVER TEMPERATURE	Protection type : Shut down o/p voltage, re-power on to recover						
		OUTPUT SHORT	Protection type : Shut down o/p voltage, re-power on to recover						
		OVER LOAD (Typ.)	105 ~ 115% load for 180 sec., 115% ~ 150% load for 10 sec.						
		CIRCUIT BREAKER	30A			16A			
		TB TYPE	UL458 (Only for "TB" AC socket)			None			
		FUNCTION	REMOTE CONTROL	Power ON-OFF remote control by front panel dry contact connector (by RELAY) Open : Normal work ; Short : Remote off					
CONNECTOR	Remote controller sold separately, Order No.: IRC1,IRC2,IRC3								
ACCESSORY	Remote controller sold separately, Order No.: IRC1,IRC2,IRC3								
AC UPS MODE	RS-232 COMMUNICATION	RS-232 ~ RJ11 Type connector							
	AC INPUT RANGE	100/110/115/120Vac±16%, recover±13%			200/220/230/240Vac±16%, recover±13%				
	FREQUENCY RANGE	45 ~ 65Hz							
	TRASFER TIME (Typ.)	10ms inverter → AC by pass							
ENVIRON-MENT	WORK TEMP.	-25 ~ +70°C (Refer to "Derating curve")							
	WORKING HUMIDITY	20 ~ 90% RH non-condensing							
	STORAGE TEMP., HUMIDITY	-30 ~ +70°C / -22 ~ +158°F, 10 ~ 95% RH non-condensing							
	VIBRATION	10 ~ 500Hz, 3G 10min./1cycle, 60min. each along X, Y, Z axes							
OTHER	MTBF	319.3K hrs min. Telcordia TR/SR-332 (Bellcore); 30.3K hrs min. MIL-HDBK-217F (25°C)							
	DIMENSION	420*270*98mm (L*W*H)							
	PACKING	8.6Kg; 1pcs/ 10.4Kg/ 1.39CUFT							

2.4 安規一覽表

Enclosure type		Socket type								
			TYPE-US	TYPE-GFCI	TYPE-UN	TYPE-EU	TYPE-CN	TYPE-AU	TYPE-UK	TYPE-TB
			In Stock	By request	In Stock	In Stock	In Stock	By request	By request	In Stock
			USA	USA	UNIVERSAL	EUROPE	CHINA	AUSTRALIA	U.K	UNIVERSAL
110Vac	NTS-300									
	NTS-450									
	NTS-750									
	NTS/NTU-1200				NA	NA	NA	NA	NA	NA
	NTS/NTU-1700									
	NTS/NTU-2200									
	NTS/NTU-3200									
220Vac	NTS-300									
	NTS-450									
	NTS-750									NA
	NTS/NTU-1200									
	NTS/NTU-1700									
	NTS/NTU-2200									
	NTS/NTU-3200									
PCB type										
110Vac	NTS-250P	 								
	NTS-400P									
220Vac	NTS-250P	 								
	NTS-400P									

2.5 減額曲線

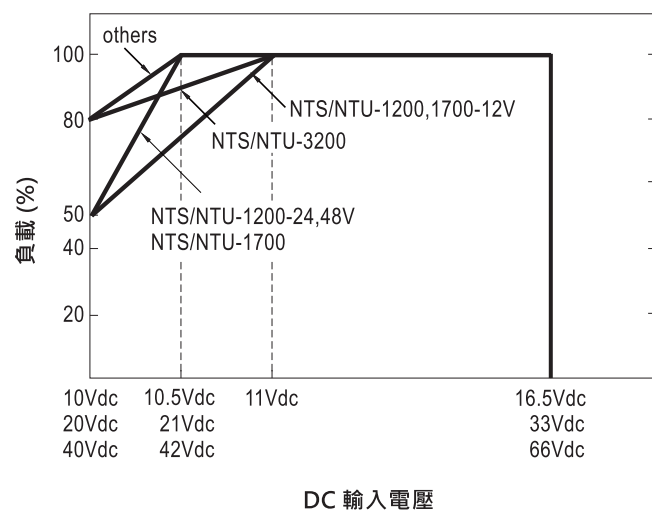
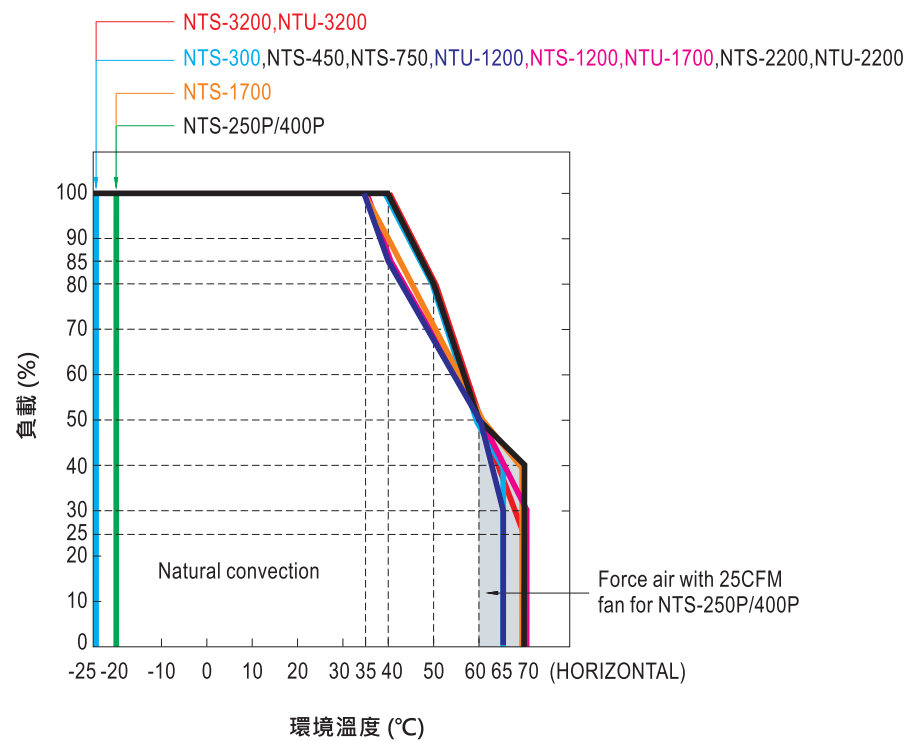

2.6 產品機構圖

NTS-250P/400P機構尺寸

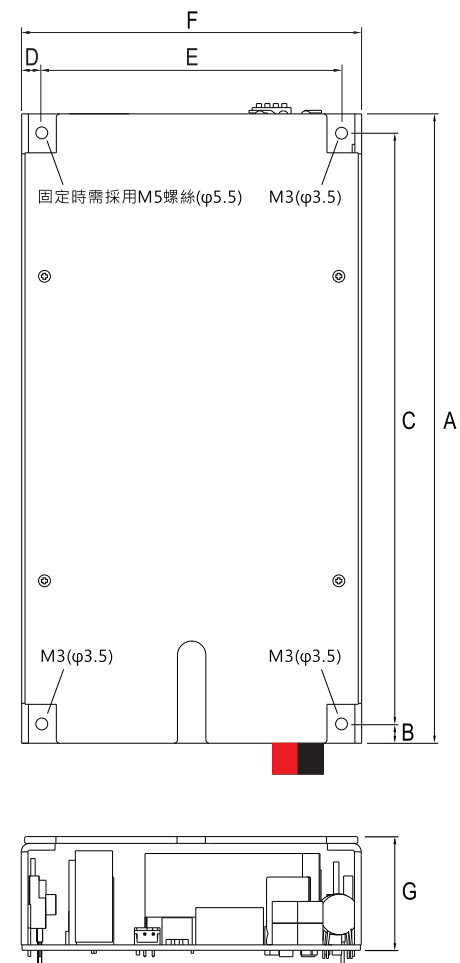

機型	A	B	C	D	E	F	G
NTS-250P	186	5.7	174.6	5.95	88.6	100.5	32
NTS-400P	186	5.7	174.6	5.95	88.6	100.5	32

單位:mm

NTS-300/450/750機構尺寸

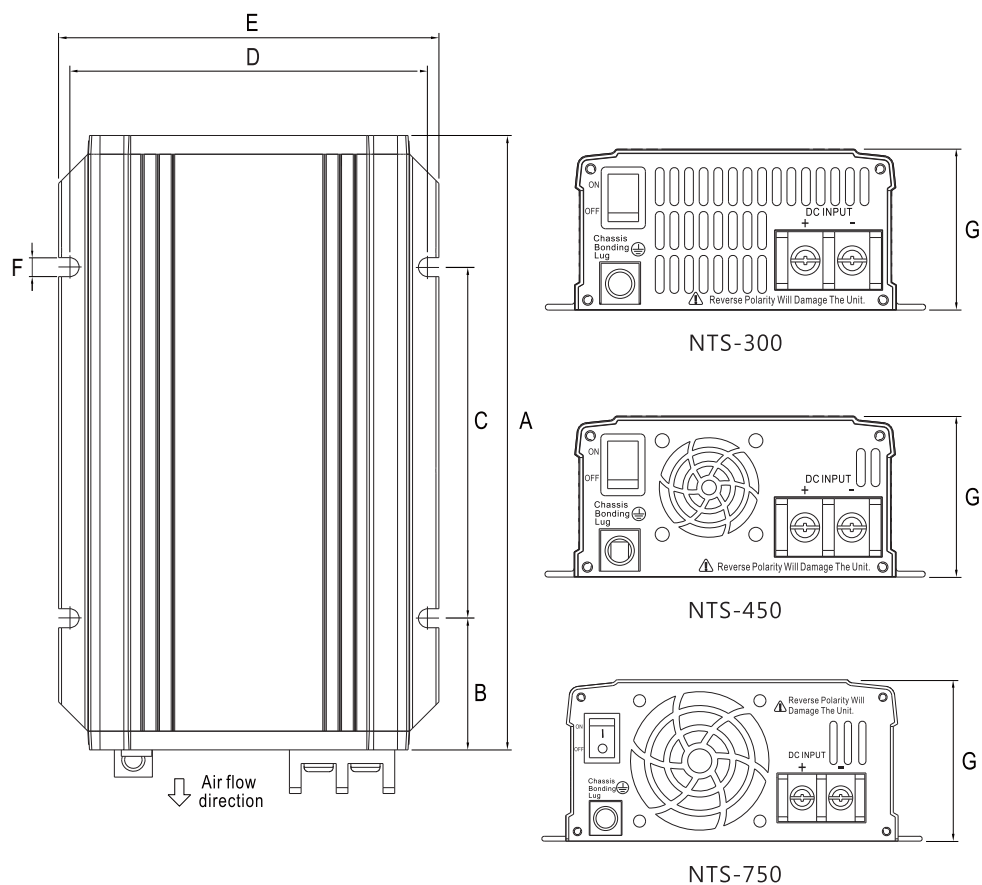

機型	A	B	C	D	E	F	G
NTS-300	210	45	120	119	130	7	55
NTS-450	210	45	120	119	130	7	55
NTS-750	270	45	180	147	158	7	67

單位:mm

NTS/NTU-1200/1700機構尺寸

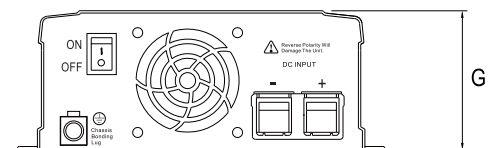
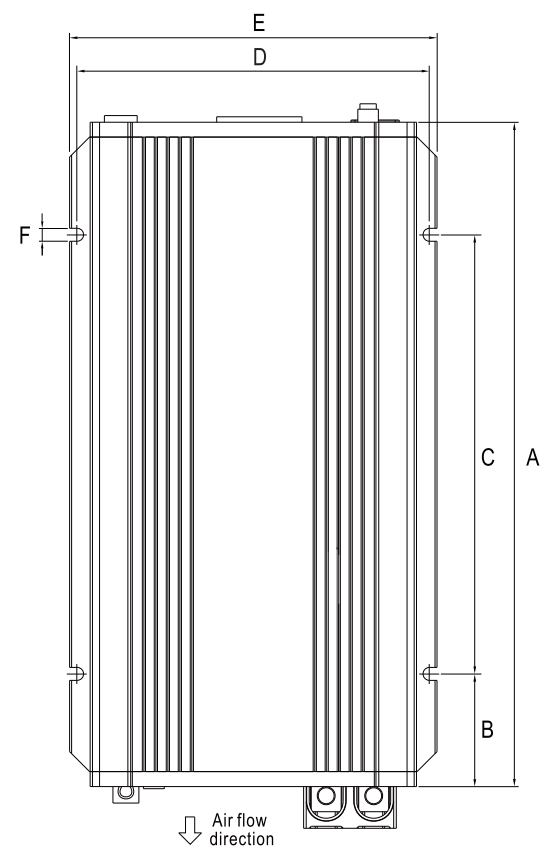

機型	A	B	C	D	E	F	G
NTS/NTU-1200	333	56.5	220	173	184	7	70
NTS/NTU-1700	400	62.5	275	173	184	7	70

單位:mm

NTS/NTU-2200/3200 機構尺寸

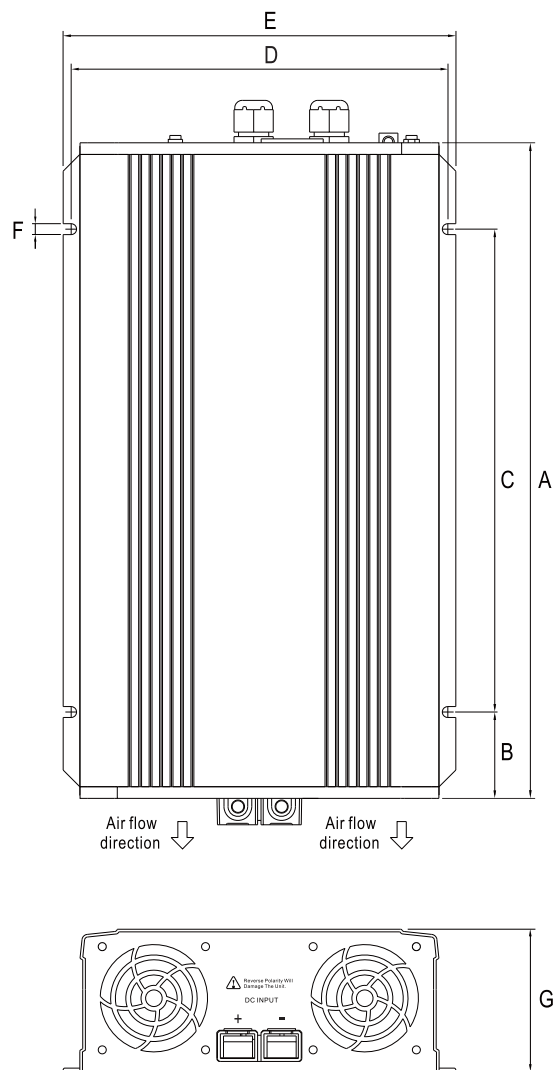

機型	A	B	C	D	E	F	G
NTS/NTU-2200	400	TBD	TBD	259	270	7.5	98
NTS/NTU-3200	440	TBD	TBD	259	270	7.5	98

單位:mm

配件(選配)

明緯訂單編號	物件	數量
RJ11-RS232		1
Carry Handle	① 提把	1
	② 腳墊	4
	③ 螺絲	2

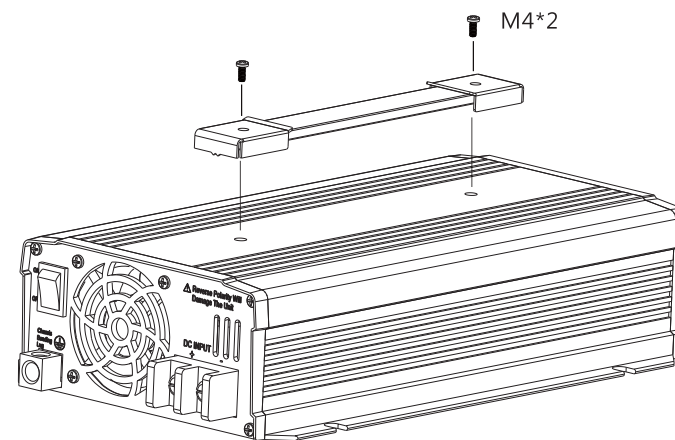

① 提把

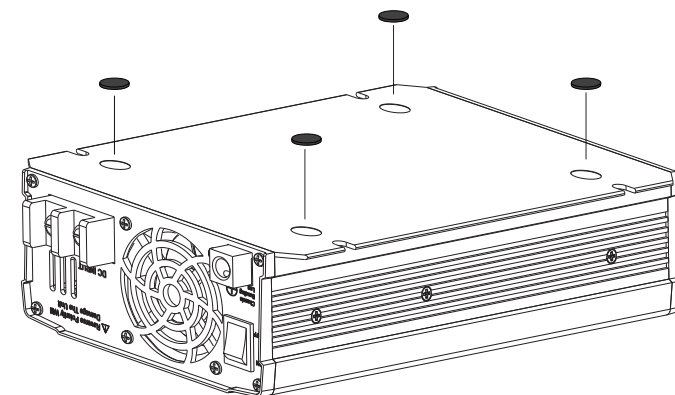

② 腳墊

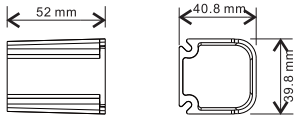

配件(標配)

	物件	數量
①	 	1
②		1
③		4

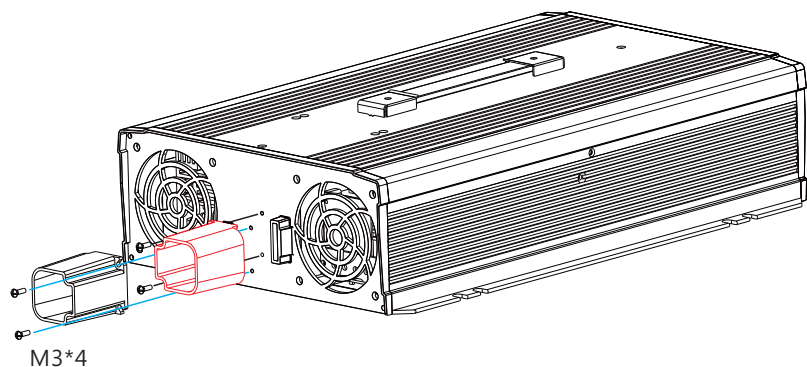

3.安裝說明

3.1 安裝注意事項

- 安裝逆變器時請留意其重量，避免系統機殼承載過重。
- 請勿使用於高溫、高溼的環境，避免影響逆變器壽命或造成故障。
- NTS-450~3200/NTU-1200~3200系列內建風扇，請保持逆變器前後面板通風口暢通，避免造成逆變器過熱保護而無法正常運行，建議出入風口至少須有15公分以上通風距離，如下示意圖：



圖3-1固定示意圖

3.2 裝配參考圖

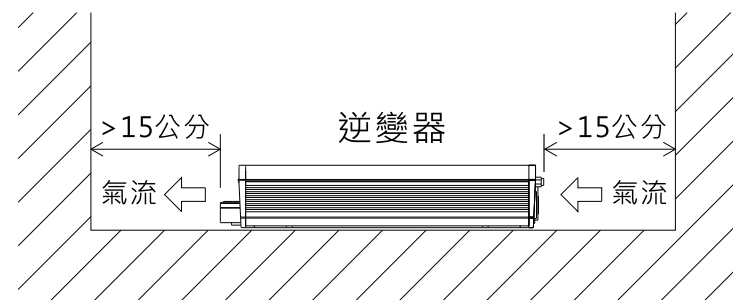

圖3-2裝配參考圖

3.3 安裝步驟

- ① 請先將逆變器關機，將ON/OFF開關切至OFF。
- ② 挑選合適線徑之線材做為連接電池及逆變器用，請參考3.4章節連接電池配線選用。
- ③ 將電池連接至逆變器DC輸入端子，電池(+)端接到輸入端子(+)，電池(-)端接到輸入端子(-)，並注意正、負極勿反接或短路。

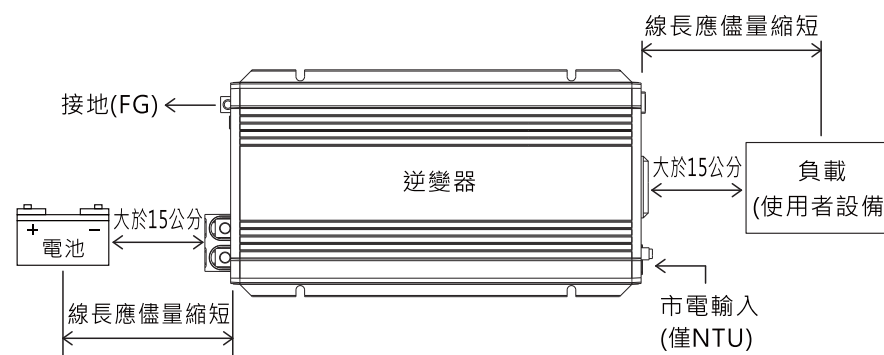

- ④ 將ON/OFF開關切至ON，狀態(Status)燈號顯示為綠燈即可正常使用。

3.4 電池配線選用

電池配線建議越短越好，且線徑選用需根據安規規定選取可承載電流量之導線。配線過細將會造成逆變器效率偏低或無法正常滿功率輸出，並且將造成線材過熱發生著火危險。請參照下表3-1：

DC額定電流(安培)	導線截面積(mm ²)	AWG
10A ~ 13A	1.25	16
13A ~ 16A	1.5	14
16A ~ 25A	2.5	12
25A ~ 32A	4	10
32A ~ 40A	6	8
40A ~ 63A	10	6
63A ~ 80A	16	4
80A ~ 100A	25	2
100A ~ 125A	35	1
125A ~ 160A	50	0

表3-1 線材使用建議表

3.5 電池組配置建議

電池種類: 鉛酸電池或鋰電池

電池電壓: 10~16.5Vdc (12V), 20~33Vdc (24V), 40~66Vdc (48V)

電池容量: 請參考下表

機型/輸出	112	212	124	224	148	248
NTS-250P	85Ah或以上		45Ah或以上		25Ah或以上	
NTS-300	100Ah或以上		50Ah或以上		30Ah或以上	
NTS-400P	150Ah或以上		70Ah或以上		35Ah或以上	
NTS-450	170Ah或以上		85Ah或以上		45Ah或以上	
NTS-750	250Ah或以上		130Ah或以上		65Ah或以上	
NTS/NTU-1200	400Ah或以上		200Ah或以上		100Ah或以上	
NTS/NTU-1700	500Ah或以上		250Ah或以上		125Ah或以上	
NTS/NTU-2200	735Ah或以上		370Ah或以上		185Ah或以上	
NTS/NTU-3200	1000Ah或以上		500Ah或以上		250Ah或以上	

3.6 GFCI 插座

為滿足UL458安規要求，需使用GFCI 插座，推薦使用以下機型 (NTU/S-2200/3200-1XXTB UL458)：

制造商	型號
Eaton	SGF20

4. 面板與燈號顯示

4.1 AC輸出側

- Ⓐ AC OUTPUT輸出插座：
因應世界各地區使用需求，可選配多種不同型式插座，詳請參考第16頁供使用者選擇。
- Ⓑ 無熔絲斷路器(No Fuse Breaker; Reset)(僅NTS-1200/1700/2200/3200 GFCI系列; NTU-1200/1700/2200/3200系列)：
在旁路(Bypass)模式下，當AC輸出短路或負載電流超過無熔絲斷路器額定電流值時，則無熔絲斷路器將開路使交流輸出斷開，停止市電直接輸出，避免危險；將不正常操作排除後再輕壓斷路器始可恢復使用。
- Ⓒ 空氣進風孔：
供逆變器散熱與穩定工作，保持通風順暢，可確保產品使用壽命。
- Ⓓ LED顯示：顯示逆變器的工作狀態及負載情形。
- Ⓔ 通訊連接埠：可另購ICR1/2/3與PC連線作遠端監控功能。
- Ⓕ POWER ON/OFF開關：
開關若切在ON的位置，則逆變器開機；切在OFF則為關機。
- Ⓖ 機殼接地端子(FG)。
- Ⓗ ON/OFF遙控接點：開路為開機(出廠)，短路為關機。
- Ⓘ AC旁路插座(僅NTU系列)：
連接到AC市電，當有市電時會直接旁路到負載設備。請使用UL認證的電源線，規格為：14 AWG/3C，SJ/SJT/SJO/SPT-3，最大長度為0.9米的接地型三線模壓連接插頭 (NEMA 5-20P)。

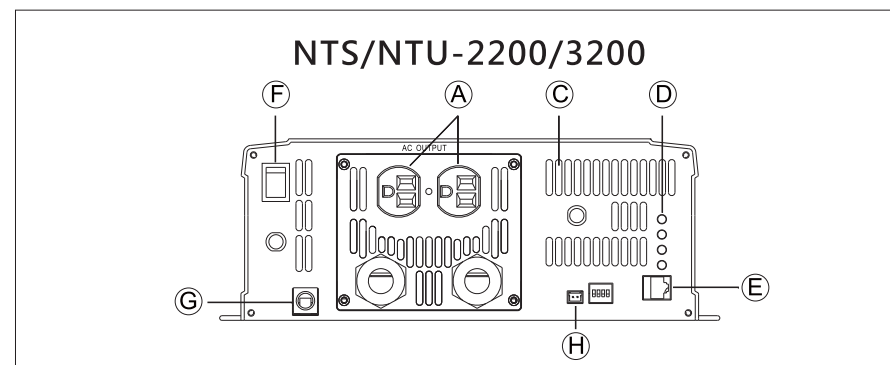
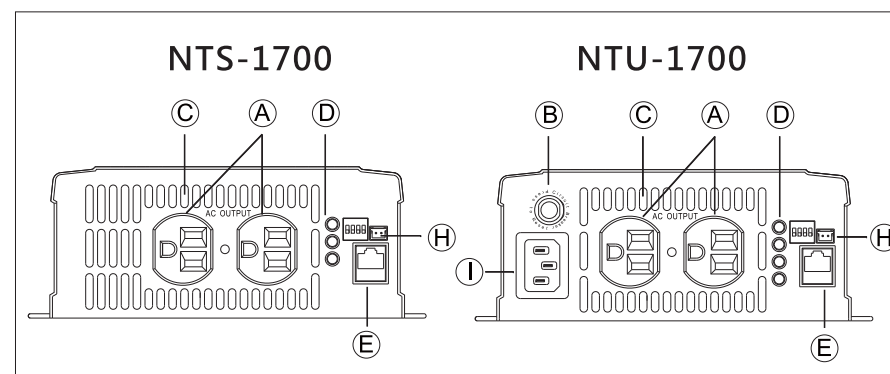
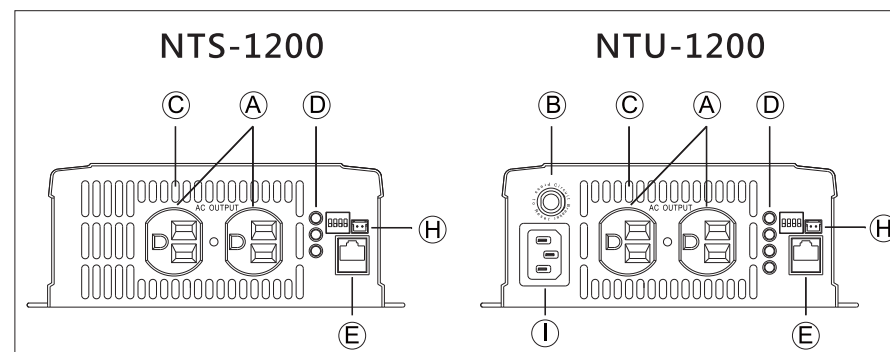
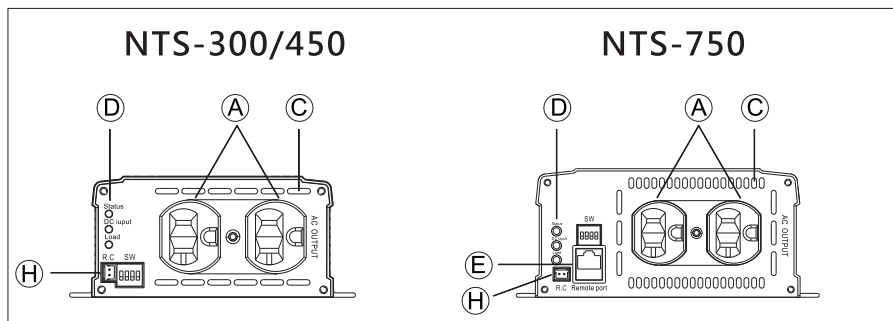

4.2 DC輸入側

- Ⓐ POWER ON/OFF開關：
開關若切在ON的位置，則逆變器開機；切在OFF的位置則為關機。
- Ⓑ 輸入端子(+),(-)。
- Ⓒ 機殼接地端子(FG)。
- Ⓓ 空氣進風孔：供逆變器散熱與穩定工作，保持通風暢通，可確保產品使用壽命。

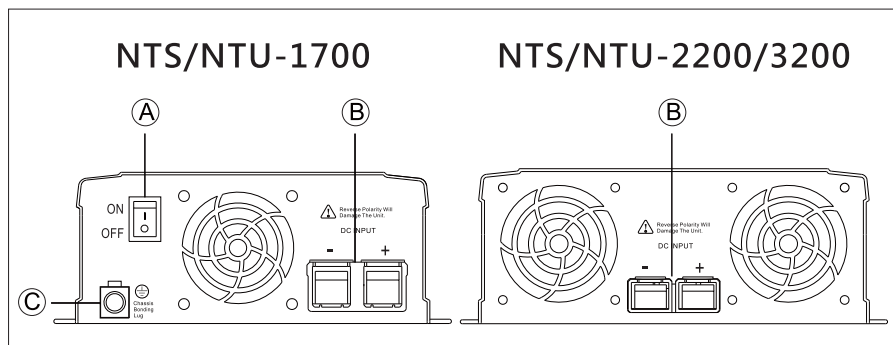
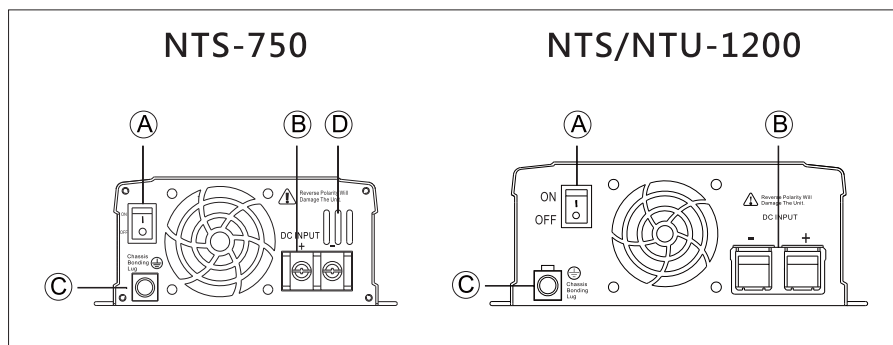
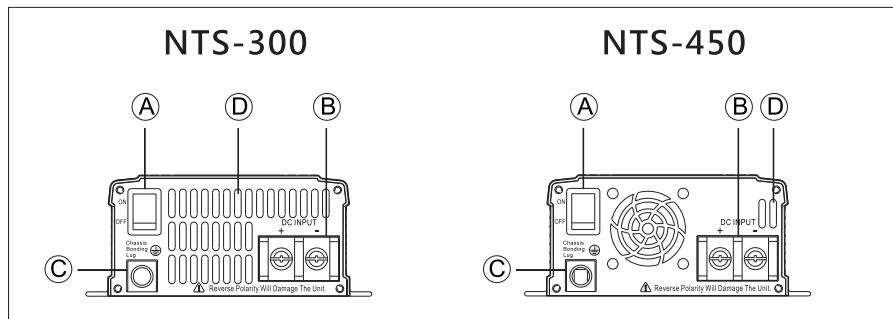

4.3 LED燈號說明

狀態燈：

用以顯示逆變器目前的狀態，包含：正常工作(Inverter OK)、遙控斷電(remote off)及省電模式(Saving mode)。

Status (狀態)	綠燈	橙燈	紅燈
	System check Inverter OK	Remote off Saving mode	Abnormal Status (See below table)

輸入燈號：

用以顯示輸入電壓狀態。

綠燈：當輸入電壓大於12.5V(12V)/25V(24V)/50V(48V)。

橘燈：當輸入電壓介於11V~12.5V(12V)/22V~25V(24V)/44V~50V(48V)

紅燈：當輸入電壓小於11V(12V)/22V(24V)/44V(48V)時或輸入電壓過高時，會閃爍紅燈及發出警報聲提醒。

DC Input (直流輸入)	綠燈	橘燈	紅燈
	12.5~15.5Vdc 25~31Vdc 50~62Vdc	11~12.5Vdc 22~25Vdc 44~50Vdc	<11Vdc or >15.5Vdc <22Vdc or >31Vdc <44Vdc or >62Vdc

負載燈號：

用以顯示使用的負載狀態。

綠燈：當負載小於40%時，顯示輕載燈號

橘燈：當負載介於40%~80%間時，顯示中載燈號

紅燈：當負載大於80%時，顯示重載燈號

Load (負載)	輸入模式	綠燈	橘燈	紅燈
	市電優先模式	<40% load	40~80% load	>80% load
電池優先模式	<40% load	40~80% load	>80% load	

AC輸入燈號：

用以顯示輸入市電的狀態。

綠燈：當市電連接且電壓正常時

閃爍綠燈：市電連接但電壓超出逆變器設定範圍的±10%時，閃爍綠燈警示

滅燈：當市電斷線或沒有連接時無顯示燈號

AC Input (交流輸入)	綠燈
	市電正常
	市電異常
未接市電	

- 恆亮
- 閃爍
- 熄滅

5.系統操作說明

5.1 輸出電壓、頻率、省電模式遙控設定

5.1.1 輸出電壓、頻率設定

出廠設定狀態為110Vac/60Hz或230Vac/50Hz，使用者可依使用需求自行切換逆變器面板上DIP S.W的SW1,2,3,4，變更輸出電壓或頻率。

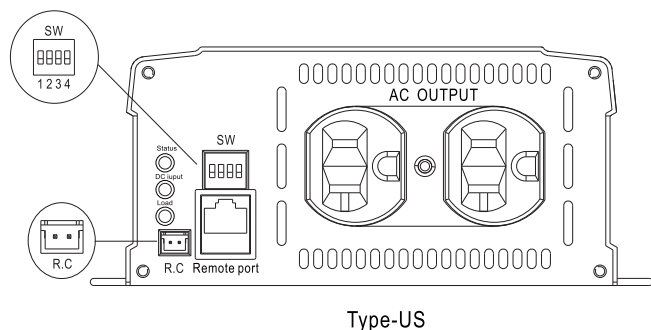

透過開關選擇AC輸出電壓、頻率、省電模式			
SW1	SW2	SW3	SW4
OFF	OFF : 100Vac or 200Vac	ON : 50Hz	ON : 省電模式
OFF	ON : 110Vac or 220Vac		
ON	OFF : 115Vac or 230Vac	OFF: 60Hz	OFF: 非省電模式
ON	ON : 120Vac or 240Vac		

5.1.2 省電模式設定

當逆變器未搭接負載時，為避免電池損耗放電過快，可將逆變器面板上DIP S.W的SW4 切換至"ON"的位置。當此模式被啟動時，搭接負載小於10W且持續3秒後，逆變器就會關閉輸出並進入省電模式。處於省電模式下，逆變器MCU定時會偵測輸出負載狀況。若有大於25W的負載搭接上，則逆變器轉換為正常模式輸出。出廠設定為非省電模式。

註：當操作於省電模式下，風扇為停轉設計。

5.1.3 遙控ON/OFF開關

R.C 開關	
開路	正常工作(出廠)
短路	停止工作

5.1.4 電池/市電優先設定

NTS-1700出廠設定為市電優先，若要進行電池優先設定，須在Remote off狀態下進行電池優先選擇的DIP切換，程式如下：

- ① 在未送電狀態下，將選擇DIP_SW的2、3撥碼開關撥至"OFF"狀態
- ② Remote off狀態下，BAT供電
- ③ 送電15s內，將DIP_SW的2、3開關都切至全"ON"，再切回全"OFF"
- ④ 所有LED燈(除AC input) 綠燈閃爍3次表示設定成功
- ⑤ 關閉NTU,外置Remote開關ON
- ⑥ 開啟NTU以載入電池優先模式

關閉電池優先設置步驟

- ① 在未送電狀態下，將選擇DIP_SW的2、3撥碼開關撥至"ON"狀態
- ② Remote off狀態下，BAT供電
- ③ 送電15s內，將DIP_SW的2、3開關都切至全"OFF"，再切回全"ON"
- ④ 所有LED燈(除AC input) 綠燈閃爍3次表示設定成功
- ⑤ 關閉NTU,外置Remote開關ON
- ⑥ 開啟NTU以載入AC優先功能

5.2 功能差異表

功能/機型	NTS-250P/400P	NTS-300/450	NTS-750/1200/1700/2200/3200	NTU-1200/1700/2200/3200
支援IRC	X	X	●	●
支援RS-232	X	X	●	●
支援UART	●	X	X	X
UPS功能	X	X	X	●
電池優先	X	X	X	●

● 標配

註：風扇轉速為溫度控制，當偵測內部溫度較低時風扇將為停轉狀態。

5.3 IRC1/IRC2/IRC3遠端監控模組

- IRC1/IRC2/IRC3是一款遠端監控模組，可搭配逆變器NTS,NTU系列使用。
- IRC1/IRC2/IRC3可以解碼逆變器內部發送的RS-232信號通過逆變器系列並透過IRC1/IRC2/IRC3數字儀表顯示。

Note: 部份遠程控制器燈號會因逆變器是實際功能而無法顯示燈號。

MODEL	IRC1	IRC2	IRC3
OUTPUT	DIGITAL METER ----- Display the battery level, output load level, and operating status of inverter unit		
	CONTROL OUTPUT Remote ON/OFF for inverter unit		
	LED INDICATOR Remote turn ON(Green) ; Remote turn Off(Orange) ; Abnormal (Red) ; Saving mode (Orange flash)		
FUNCTION	REMOTE ON/OFF CONTROL The controlled inverter unit can be turned ON/OFF on the remote control panel for IRC1 / IRC2 / IRC3		
	POWER SAVING CONTROL Power saving enable / disable activation		
	SUITABLE SERIES TS-700 / 1000 / 1500 / 3000 TN-1500 / 3000 NTS-750 / 1200 / 1700 / 2200 / 3200 NTU-1200 / 1700 / 2200 / 3200	TS-700 / 1000 / 1500 / 3000 NTS-750 / 1200 / 1700 / 2200 / 3200 NTU-1200 / 1700 / 2200 / 3200	TN-1500 / 3000 NTS-750 / 1200 / 1700 / 2200 / 3200 NTU-1200 / 1700 / 2200 / 3200
ENVIRONMENT	WORKING TEMP. -20 ~ +50℃		
	WORKING HUMIDITY 20 ~ 90% RH non-condensing		
	STORAGE TEMP., HUMIDITY -40 ~ +85℃, 10 ~ 95% RH non-condensing		
	VIBRATION 10 ~ 500Hz, 2G 10min./1cycle, 60min. each along X, Y, Z axes		
EMC	EMC EMISSION Compliance to EN55032 class A, EN61000-3-2,3, FCC PART 15 class A		
	EMC IMMUNITY Compliance to EN61000-4-2,3,4,6,8		
OTHER	DIMENSION (L*W*H) (Unit:mm) 186*100.5*32mm (L*W*H)		
	PACKING 0.75Kg; 18pcs/ 14.5Kg/ 0.97CUFT		
NOTE	1. The remote control can not re-power on for inverter at abnormal status. 2. The ambient temperature derating of 3.5℃/1000m with fanless models and of 5℃/1000m with fan models for operating altitude higher than 2000m(6500ft). ※ Product Liability Disclaimer : For detailed information, please refer to https://www.meanwell.com/serviceDisclaimer.aspx		

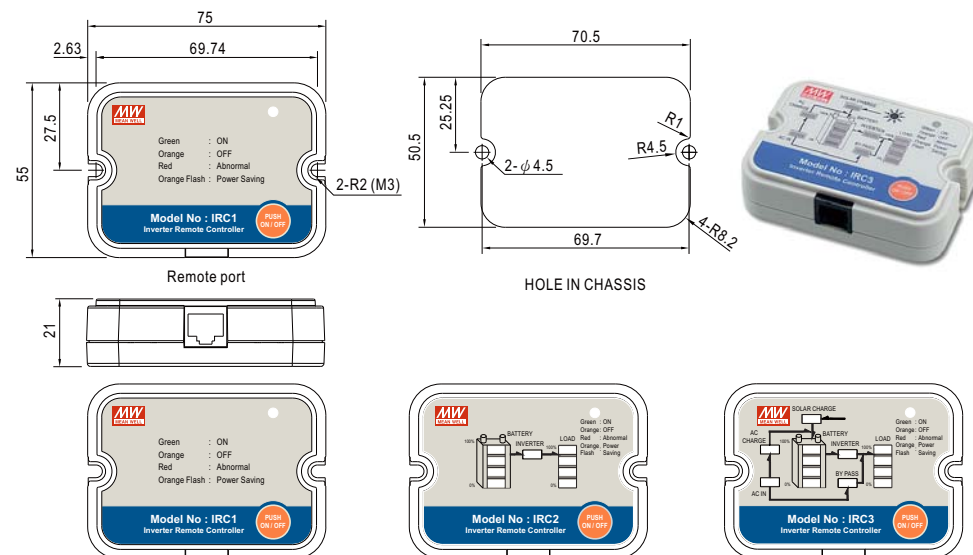

5.4 RS-232/UART通訊

5.4.1 NTS/NTU系列產品與外部控制器(Controller)/PC軟體之間可通過RS-232/UART通訊傳輸。通過通訊可以設定或讀取單台NTU/NTS內部資料，配置上不能使用多台並聯。

通訊實體層設置如下：

Control	Setting
Baud Rate	9600
Data Bits	8
Stop Bit	1
Parity	None
Flow Control	None

通訊命令如下定義：

命令	型態	型態
Q	R	Status Inquiry
C	W	Remote Control INVERTER
V	R/W	Write voltage/Frequency Write:需先以“pU”命令進行解鎖
pU	W	適用於設定命令的解鎖，Enable setting mode (for “V”) 時效性只有一次的命令
I	R	INVERTER Information
W	W	Write Information into INVERTER EEPROM
U	R/W	Write UVP Transfer voltage、OVP Transfer voltage

通訊時序

Min. request period (Controller/PC to NTU/NTS): 500mSec。

Max. response time (NTU/NTS to Controller/PC): 15mSec。

Min. packet margin time (Controller/PC to NTU/NTS): 10mSec。

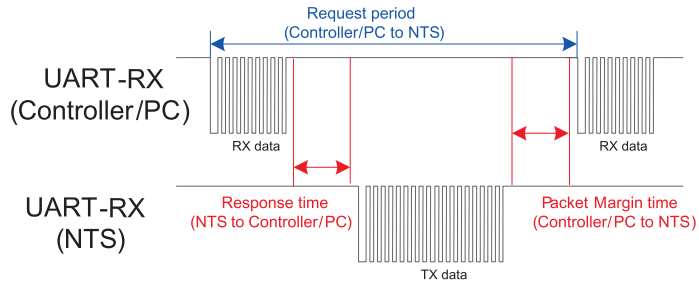

協定寫入及回覆框架

NTS/NTU通訊傳輸使用ASCII碼。資料框結束字元判斷以CR(0x0D)為主。不過一般常見結束字元表示方式還有CRLF(0x0D 0x0A)。因此在資料解碼時，需留意資料是否帶有LF(0x0A)，如有請進行清除以避免造成資料混亂。為了提升傳輸品質，部分指令含checksum。

Checksum計算方式如下：

先將需要計算checksum數據中的checksum歸零。

將checksum之前所有的資訊加總，包含命令指令(例如: V或I)。

加總後數據小於2 bytes，則補0湊足為2bytes。

以V指令設定逆變器輸出為110Vac/50Hz為例，V指令寫入格式如下：

0	1-3	4	5-7	8-9	10
V(0x56)	Voltage	SP(0x20)	Frequency	Checksum	CR(0x0D)

將指令填入格式後，除checksum以外，指令數據為：

V(0x56)	1(0x31)	1(0x31)	0(0x30)	SP(0x20)	0(0x30)	5(0x35)	0(0x30)	checksum	CR(0x0D)
---------	---------	---------	---------	----------	---------	---------	---------	----------	----------

① 先將checksum清零

② Checksum為checksum之前所有寫入數據的總和

$$\text{Sum} = 56 + 31 + 31 + 30 + 20 + 30 + 35 + 30 = 19D$$

③ Checksum = 01 9D

V指令寫入格式數據則為：

V(0x56)	1(0x31)	1(0x31)	0(0x30)	SP(0x20)	0(0x30)	5(0x35)	0(0x30)	0x019D	CR(0x0D)
---------	---------	---------	---------	----------	---------	---------	---------	--------	----------

NOTE: 詳細V指令設定格式，請參考以下V指令寫入/讀取格式及定義說明。

Q指令: 用於確認逆變器狀態。可確認參數為輸出電壓、輸出功率(百分比%)、輸入電池電壓、電池容量比例、溫度、輸入市電電壓、輸出電壓頻率、DC bus電壓、輸出功率等。

寫入格式:

0	1
Q(0x51)	CR(0x0D)

回覆格式:

0	1~3	4	5~7	8	9~12	13	14~16
((0x28)	O/P Voltage	SP(0x20)	O/P load (Digital)	SP(0x20)	Battery voltage	SP(0x20)	Battery capacity
17	18~21	22	23~25	26	17~30	31	32~34
SP(0x20)	Heat Sink Temperature	SP(0x20)	Utility Power Volt.	SP(0x20)	Output Power Freq.	SP(0x20)	DC BUS Voltage
35	36~38	39	40	41	42	43	44
SP(0x20)	O/P Load (Analog)	SP(0x20)	b0	b1	b2	b3	b4
45	46	47	48	49	50	51	52
b5	b6	b7	b8	b9	b10	b11	b12
53	54	55	56	57	58	59	60
b13	b14	b15	b16	b17	b18) (0x29)	CR(0x0D)

命令(Q)內容定義

命令Q 49 byte 資料流		(VVV QQQ SS.S BBB TT.T MMM RR.R DDD PPP b0b1b2b3b4b5b6b7b8b9b10b11b12b13b14b15b16b17b18)				
Byte數	資料名稱	敘述	R/W	數值範圍	資料型態	單位
VVV,3	O/P Voltage	輸出電壓	R	0~250Vac	U1	ASCII
QQQ,3	O/P load percent (Digital)	輸出功率 (百分比)	R	0% =000 0 < ~ ≤30% =025 31 < ~ ≤50% =050 51 < ~ ≤75% =075 76 < ~ % =100	U1	ASCII
SS.S,4	Battery voltage	輸入電池電壓	R	12: 0~17.0Vdc 24: 0~34.0Vdc 48: 0~68.0Vdc	U1	ASCII
BBB,3	Battery capacity	電池容量比例	R	0 ≤ ~ < 25% =025 26 < ~ ≤ 50% =050 51 < ~ ≤ 75% =075 76 < ~ ≤ 100% =100	U1	ASCII
TT.T,4	Heat Sink Temperature	溫度	R	0~99.9°C	U1	ASCII
MMM,3	Utility Power Voltage	輸入市電電壓	R	0~250Vac	U1	ASCII
RR.R,4	Output Power Frequency	輸出電壓頻率	R	40.0~70.0 Hz	U1	ASCII
DDD,3	DC BUS Voltage	DC bus 電壓	R	0V	U1	ASCII
PPP,3	O/P load Percent (Analog)	輸出功率 (百分比數值)	R	0~100%	U1	ASCII
b0,1	INVERTER Mode	INVERTER Mode	R	1: INVERTER Mode	U1	ASCII
b1,1	Bypass Mode	Bypass Mode	R	1: Bypass Mode	U1	ASCII
b2,1	Utility Power supply	Utility Power supply	R	1: Utility Power	U1	ASCII

命令Q 49 byte 資料流		(VVV QQQ SS.S BBB TT.T MMM RR.R DDD PPP b0b1b2b3b4b5b6b7b8b9b10b11b12b13b14b15b16b17b18)				
Byte數	資料名稱	敘述	R/W	數值範圍	資料型態	單位
b3,1	Utility Charger Enable	Utility Charger Enable	R	1: Enable	U1	ASCII
b4,1	Solar Charger Enable	Solar Charger Enable	R	1: Enable	U1	ASCII
b5,1	Saving Mode Occurred	Saving Mode Occurred	R	1: Saving Mode	U1	ASCII
b6,1	Battery Exhausted Mode	Battery Exhausted Mode	R	1: Battery low	U1	ASCII
b7,1	Shutdown Mode (Battery used up)	Shutdown Mode (Battery used up)	R	1: 電池沒電停機	U1	ASCII
b8,1	Battery OVP	Battery OVP	R	1: Battery OVP	U1	ASCII
b9,1	遠端控制 Shutdown INVERTER	遠端控制 Shutdown INVERTER	R	1: Remote Shutdown	U1	ASCII
b10,1	OLP 100 ~ 115%	OLP 100 ~ 115%	R	1: Occurred OLP 100%~	U1	ASCII
b11,1	OLP 115 ~ 150%	OLP 115 ~ 150%	R	1: Occurred OLP 115%~	U1	ASCII
b12,1	OLP 150% ~	OLP 150% ~	R	1: Occurred OLP 150%~	U1	ASCII
b13,1	OTP	OTP	R	1: Inverter OTP 2: Fan lock protection	U1	ASCII
b14,1	INV UVP	INV UVP	R	1: INV UVP protection	U1	ASCII
b15,1	INV OVP	INV OVP	R	1: INV OVP protection	U1	ASCII

Byte數	資料名稱	敘述	R/W	數值範圍	資料型態	單位
b16,1	INV Fault	INV Fault	R	1: INV Fault	U1	ASCII
b17,1	EEPROM error code	EEPROM error code	R	1: EEPROM error	U1	ASCII
b18,1	System Shutdown	System Shutdown	R	1: Shutdown	U1	ASCII

C指令: 用於遠端遙控開關逆變器。

寫入格式:

Remote OFF

0	1	2	3	4	5	6	6	8
C(0x43)	1(31)	0(30)	0(30)	0(30)	0(30)	0(30)	0(30)	0(30)
9	10	11	12	13	14	15	16	
0(30)	0(30)	0(30)	0(30)	0(30)	0(30)	0(30)	CR(0x0D)	

Remote ON

0	1	2	3	4	5	6	6	8
C(0x43)	0(30)	1(31)	0(30)	0(30)	0(30)	0(30)	0(30)	0(30)
9	10	11	12	13	14	15	16	
0(30)	0(30)	0(30)	0(30)	0(30)	0(30)	0(30)	CR(0x0D)	

回覆格式:

0
C(0x43)

命令(C)內容定義

命令C 15 byte資料流		(Cb0b1b2b3b4b5b6b7b8b9b10b11b12b13b14)				
Byte數	資料名稱	敘述	R/W	數值範圍	資料型態	單位
b0,1	Shut down	Shut down	W	1: Remote Shutdown	U1	ASCII
b1,1	Turn on INVERTER	Turn on INVERTER	W	1: Remote On INV	U1	ASCII
b2,1	保留	保留		固定" 0x30"	U1	ASCII
b3,1	保留	保留		固定" 0x30"	U1	ASCII
b4,1	保留	保留		固定" 0x30"	U1	ASCII
b5,1	保留	保留		固定" 0x30"	U1	ASCII
b6,1	保留	保留		固定" 0x30"	U1	ASCII

Byte數	資料名稱	敘述	R/W	數值範圍	資料型態	單位
b7,1	保留	保留		固定" 0x30"	U1	ASCII
b8,1	保留	保留		固定" 0x30"	U1	ASCII
b9,1	保留	保留		固定" 0x30"	U1	ASCII
b10,1	保留	保留		固定" 0x30"	U1	ASCII
b11,1	保留	保留		固定" 0x30"	U1	ASCII
b12,1	保留	保留		固定" 0x30"	U1	ASCII
b13,1	保留	保留		固定" 0x30"	U1	ASCII
b14,1	保留	保留		固定" 0x30"	U1	ASCII

V指令: 用於變更輸出電壓及頻率使用。每次執行" V" 指令前, 需先以" pU" 命令解鎖, 才可傳送命令。

寫入格式:

0	1	2						
①	pU(0x70 0x55)	CR(0x0d)	(傳送後需延遲最少20ms後, 才可進行電壓電流變更)					
	0	1~3	4	5~7	8	9	10	
②	V(0x56)	Voltage	SP(0x20)	Frequency	Checksum	CR(0x0D)		

回覆格式:

若傳送設定參數正確, 則逆變器回覆:

0	1~3	4	5~7	8	9	10
#(0x23)	Voltage	SP(0x20)	Frequency	Checksum	CR(0x0D)	

若傳送設定參數不正確, 則逆變器回覆如下: 請確認後重傳。

0	1	2	3	4	5	6	7	8
#(0x23)	V(0x56)	SP(0x20)	C(0x43)	M(0x4D)	D(0x44)	SP(0x20)	E(0x43)	R(0x52)
0	1	2	3	4				
R(0x52)	O(0x4F)	R(0x52)	Checksum	CR(0x0D)				

命令(V)內容定義

命令V 8 byte資料流		(VWWW FFF)				
Byte數	資料名稱	敘述	R/W	數值範圍	資料型態	單位
WWW,3	Voltage	電壓設定	W/R	110系列 100~120 : 100~120Vac	U1	ASCII
				220系列 200~240 : 200~240Vac		
				000 : 恢復出廠電壓設定 (以DIP switch設定模式) 備註		
FFF,3	Frequency	頻率設定	W/R	050 : 50Hz 060 : 60Hz 000 : 恢復出廠頻率設定 (以DIP switch設定模式) 備註	U1	ASCII
2	Checksum	資料內容 總和(不含 Checksum)				

備註：透過“V”指令設定電壓或頻率後，斷開通訊，產品仍可維持設定值。如想切換回DIP Switch設定，電壓及頻率請下0 (0x30) 0 (0x30) 0 (0x30)，重新開機後新設定即可生效。

I指令：用於讀取逆變器資訊，可以讀取逆變器輸出電壓、頻率、電壓機型以及電池均充電壓、浮充電壓、告警電壓、停機電壓等。

寫入格式:

0	1
I(0x49)	CR(0x0D)

回覆格式:

0	1	2	3	4~7	8	9~12	13
#(0x23)	Voltage & Freq.	Saving mode	Model Code	Equalization Volt.	SP(0x20)	Floating Volt.	SP(0x20)
14~17	18	19~22	23	24~27	28	29~38	39
Alarm Volt.	SP(0x20)	Shutdown Volt.	SP(0x20)	Transfer Volt.	SP(0x20)	Manufacture Country	SP(0x20)
40~58	59	60~68	69	70~82	83	84	85
Serial Number	SP(0x20)	Revision	SP(0x20)	Model Name	SP(0x20)	Battery First Flag	SP(0x20)

86~95	96 97	98
Date	Checksum	CR(0x0D)

W指令：用於修改逆變器規格，可修改告警電、停機電壓、序號、機型名稱、設定電池優先模式和AC優先模式等。

寫入格式:

0	1	2	3	4~7	8	9~12	13
W(0x57)	Voltage & Freq.	Saving mode	Model Code	Equalization Volt.	SP(0x20)	Floating Volt.	SP(0x20)
14~17	18	19~22	23	24~27	28	29~38	39
Alarm Volt.	SP(0x20)	Shutdown Volt.	SP(0x20)	Transfer Volt.	SP(0x20)	Manufacture Country	SP(0x20)
40~58	59	60~68	69	70~82	83	84	85
Serial Number	SP(0x20)	Revision	SP(0x20)	Model Name	SP(0x20)	Battery First Flag	SP(0x20)

86~95	96 97	98
Date	Checksum	CR(0x0D)

回覆格式:

若傳送設定參數正確，則逆變器回覆:

0	1	2	3	4~7	8	9~12	13
#(0x23)	Voltage & Freq.	Saving mode	Model Code	Equalization Volt.	SP(0x20)	Floating Volt.	SP(0x20)
14~17	18	19~22	23	24~27	28	29~38	39
Alarm Volt.	SP(0x20)	Shutdown Volt.	SP(0x20)	Transfer Volt.	SP(0x20)	Manufacture Country	SP(0x20)
40~58	59	60~68	69	70~82	83	84	85
Serial Number	SP(0x20)	Revision	SP(0x20)	Model Name	SP(0x20)	Battery First Flag	SP(0x20)

86~95	96 97	98
Date	Checksum	CR(0x0D)

若傳送設定參數不正確，則逆變器回覆如下。

0	1	2	3	4	5	6	7	8
#(0x23)	W(0x57)	SP(0x20)	C(0x43)	M(0x4D)	D(0x44)	SP(0x20)	E(0x43)	R(0x52)
0	1	2	3	4				
R(0x52)	O(0x4F)	R(0x52)	Checksum	CR(0x0D)				

命令(I、W)內容定義

命令I、W 87 byte 資料流		(I/WVDMEE.E FF.F AA.A SS.S TT.T MEANWELL LOC-XXXXXXXXXXXXXXXXX vv.v XXXXXXXXXXXXXXXX B MM/DD/YYYY)				
Byte數	資料名稱	敘述	R/W	數值範圍	資料型態	單位
V,1	Voltage & Freq.	電壓/頻率檔位選擇	R	100V(200V)/50Hz=00 110V(220V)/50Hz=01 115V(230V)/50Hz=02 120V(240V)/50Hz=03 100V(200V)/60Hz=04 110V(220V)/60Hz=05 115V(230V)/60Hz=06 120V(240V)/60Hz=07 (由DIP SW決定)(備註1)	U1	Binary
D,1	Savingmode	Saving 控制	R	Disable=00 Enable=01 (由DIP SW決定)(備註1)	U1	Binary
M,1	Model Code	電壓機型選擇	R	112=00 124=01 148=02 212=03 224=04 248=05 (由DIP SW決定)(備註1)	U1	Binary
EE.E,4	Equalization Volt.	均充電壓設定點	W/R	12: 9.0~15.0Vdc 24: 18.0~30.0Vdc 48: 36.0~60.0Vdc (不支持修改)(備註2)	U1	ASCII
FF.F,4	Floating Volt.	浮充電壓設定點	W/R	12: 9.0~15.0Vdc 24: 18.0~30.0Vdc 48: 36.0~60.0Vdc (不支持修改)(備註2)	U1	ASCII
AA.A,4	Alarm Volt.	告警電壓設定點	W/R	12: 9.9~12.5Vdc 24: 19.8~25.0Vdc 48: 39.6~50.0Vdc (備註3)	U1	ASCII

Byte數	資料名稱	敘述	R/W	數值範圍	資料型態	單位
SS.S,4	Shutdown Volt.	停機電壓設定點	W/R	12: 9.7~12.0Vdc 24: 19.4~24.0Vdc 48: 38.8~48.0Vdc (備註3)	U1	ASCII
TT.T,4	Transfer Volt.	轉換電壓設定點	W/R	12: 9.0~15.0Vdc 24: 18.0~30.0Vdc 48: 36.0~60.0Vdc (不支持修改)(備註2)	U1	ASCII
10	Manufacture Country	製造商	W/R	MEANWELL (備註4)	U1	ASCII
19	Serial Number	序號	W/R	LOC-XXXXXXXXXXXXXXXXX (x: 0~9 數字)	U1	ASCII
9	Revision	版本	R	REV:vv.v (版本為韌體定義，不可被修改)	U1	ASCII
13	Model Name	機型名稱	W/R	依各機型定義 (最多14碼)	U1	ASCII
B,1	Battery First Flag	電池輸出優先	W/R	0 = Disable 1 = Enable	U1	ASCII
10	Date	日期	W/R	日期格式: MM/DD/YYYY	U1	ASCII
2	Checksum	資料內容總和(不含Checksum)				

- ① 讀取值為任意字符代碼，寫入時滿足Byte長度，數值任意值。
- ② 如相關參數不支持修改時，設定寫入時，以最大電壓為主：
 12: 15.0V(0x31 0x35 0x2E 0x30)
 24: 30.0V(0x33 0x30 0x2E 0x30)
 48: 60.0V(0x36 0x30 0x2E 0x30)
- ③ 電池電壓設定需滿足以下條件： $12.5V \geq \text{Alarm_Volt.} > \text{Shutdown_Volt.} \geq 9.7V$ 。且需滿足 $\text{Alarm_Volt.} - \text{Shutdown_Volt.} \geq 0.2V$ 。若不滿足上述條件，則設定無效。
- ④ 如果資料無法補滿時，以空白(0x20)碼寫入。
 例如：製造商“MEAN WELL”為8位，需補2位。ASCII碼應為：

M(0x4D)	E(0x45)	A(0x41)	N(0x4E)	W(0x57)	E(0x45)	L(0x4C)	L(0x4C)	0(0x20)	0(0x20)
---------	---------	---------	---------	---------	---------	---------	---------	---------	---------

U指令：用於電池優先模式下電池欠壓轉換電壓設定、電池過壓轉換電壓設定，僅適用於NTU機型。

寫入格式：

0	1~4	5	6~9	10	11~14	15	16~19
#(0x55)	UVP Transfer Voltage	SP(0x20)	OVP Transfer voltage	SP(0x20)	V1	SP(0x20)	V2
20	21~24	25	26~29	30 31	32		
SP(0x20)	V3	SP(0x20)	V4	Checksum	CR(0x0D)		

注:V1、V2、V3、V4為預留參數，均為4 bytes，內容為固定值：0x30 0x30 0x2E 0x30。

回復格式：

若Controller/PC傳送設定參數正確，則NTU回覆:

0	1~4	5	6~9	10	11~14	15	16~19
#(0x23)	UVP Transfer Voltage	SP(0x20)	OVP Transfer voltage	SP(0x20)	V1	SP(0x20)	V2
20	21~24	25	26~29	30 31	32		
SP(0x20)	V3	SP(0x20)	V4	Checksum	CR(0x0D)		

若Controller/PC傳送設定參數不正確，則NTU回復：請確認後重傳。

0	1	2	3	4	5	6	7	8
#(0x23)	U(0x55)	SP(0x20)	C(0x43)	M(0x4D)	D(0x44)	SP(0x20)	E(0x43)	R(0x52)
9	10	11	12~13	14				
R(0x52)	O(0x4F)	R(0x52)	Checksum	CR(0x0D)				

命令(U)內容定義：

Byte數	資料名稱	敘述	R/W	數值範圍	資料型態	單位
4	UVP Transfer Voltage	電池優先模式： 電池欠壓轉換電壓設定 備註1	W/R	12:9.9~12.5Vdc 24:19.8~25.0Vdc 48:39.6~50.0Vdc Default: 12: 11Vdc 24: 22Vdc 48: 44Vdc 備註2	U1	ASCII
4	OVP Transfer Voltage	電池優先模式： 電池過壓轉換電壓設定 備註1	W/R	12:10.5~15.5Vdc 24:21.0~32.0Vdc 48:42.0~64.0Vdc Default: 12: 14.4Vdc 24: 28.8Vdc 48: 57.6Vdc 備註2	U1	ASCII
4	V1	保留位	W/R	固定值 0x30 0x30 0x2E 0x30	U1	ASCII
4	V2	保留位	W/R	固定值 0x30 0x30 0x2E 0x30	U1	ASCII
4	V3	保留位	W/R	固定值 0x30 0x30 0x2E 0x30	U1	ASCII
4	V4	保留位	W/R	固定值 0x30 0x30 0x2E 0x30	U1	ASCII
4	Checksum	資料內容總和 (不含 Checksum)			U1	ASCII

備註:

- 電池優先模式下，觸發OVP的前提是觸發UVP，電池電壓到達UVP轉換點後，切換為AC供電，並給電池進行充電；電池電壓到達OVP轉換點後，切換為DC供電，由電池進行放電。
 (在電池優先模式下，電池電壓低於設定的電池欠壓轉換電壓，切到AC供電；等到電池電壓到達設定的電池過壓轉換電壓後，切回DC模式。)

2. 電池電壓設定需滿足以下條件(以12V機型為例)：
 $9.9 \leq \text{UVP Transfer Voltage} \leq 12.5$ 、 $10.5 \leq \text{OVP Transfer voltage} \leq 15.5$ 、
 $\text{OVP Transfer voltage} - \text{UVP Transfer Voltage} > 0.2$ 。若不滿足上述條件，則設定無效。

當W指令裡面的Shutdown Volt \geq UVP Transfer Voltage時，UVP Transfer Voltage設定值如下：
 12V設定值為Shutdown Volt+0.5V、24V設定值為Shutdown Volt+1V、48V設定值為Shutdown Volt+2V。

若設定後UVP Transfer Voltage \geq OVP Transfer voltage，OVP Transfer voltage設定值如下：
 12V 設定值為UVP Transfer Voltage+0.5V、24V設定值為UVP Transfer Voltage+1V、48V設定值為UVP Transfer Voltage+2V。

5.4.2 通訊實務操作

以下將提供RS-232/UART通訊範例。

1. 後端控制器DB9端的PIN3、PIN5、PIN2接至NTS-750-248UN通訊端子RJ11的Rx(PIN2),GND(PIN3),Tx(PIN4)。
2. 通訊實體層設置如下：

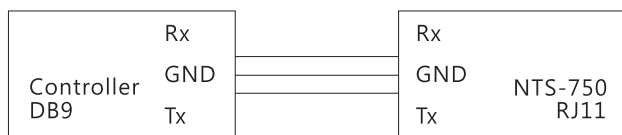

Control	Setting
Baud Rate	9600
Data Bits	8
Stop Bit	1
Parity	None
Flow Control	None

3 Q指令傳輸

以NTS-750-248UN機型為例，讀取逆變器狀態

請求指令：51 0D

回傳指令：28 32 33 30 20 30 32 35 20 34 38 2E 33 20 30 37 35 20 32 30 2E 30 20 30 30 30 20 35 30 2E 30 20 30 30 30 20 30 32 33 20 31 30 30 30 30 30 30 30 30 30 30 30 30 29 0D

請求指令解釋：

數位	0	1
輸入	51	0D
功能	Q 指令確認	結束符
解釋	Q 指令寫入	指令結束

回傳指令解釋：

數位	0	1-3	4	5-7	8	9-12	13	14-16
回傳	28	32 33 30	20	30 32 35	20	34 38 2E 33	20	30 37 35
功能	左括弧	輸出電壓	間隔符號	輸出功率(百分比)	間隔符號	輸入電壓	間隔符號	電池容量
解釋	(230V	空格	0 < ~ ≤ 30%	空格	48.3V	空格	51% < ~ ≤ 75%

17	18~21	22	23~25	26	27~30	31	32~34	35	36~38
20	32 30 2E 30	20	30 30 30	20	35 30 2E 30	20	30 30 30	20	30 32 33
間隔符號	溫度	間隔符號	輸入市電電壓	間隔符號	輸出電壓頻率	間隔符號	DC Bus 電壓	間隔符號	輸出功率(百分比數值)
空格	20.0 °C	空格	0V	空格	50Hz	空格	0V	空格	23%

39	40	41	42	43	44	45	46	47	48
20	31	30	30	30	30	30	30	30	30
間隔符號	INVERTER Mode 檢測	Bypass Mode 檢測	Utility Power 檢測	Utility Charge 檢測	Solar Charger 檢測	Saving Mode 檢測	Battery Exhausted Mode 檢測	Shutdown Mode 檢測	Battery OVP 檢測
空格	處於逆變器模式	未處於Bypass 模式	未接公共電源	未接公共充電器	未接太陽能充電器	為非省電模式	電池未處於欠壓模式	未處於電池無電狀態	電池未處於過壓狀態

49	50	51	52	53	54	55	56	57	58
30	30	30	30	30	30	30	30	30	30
遙控 關閉 逆變 器	OLP 100~ 115%	OLP 115~ 150%	OLP 150%~	OTP	INV UVP	INV OVP	INV Fault	EEPROM Error code	System Shutdo Wn
未處 於遙 控關 機狀 態	負載未 達到100 ~115% 的額定 負載	負載未 達到115 ~150% 的額定 負載	負載未 達到 150%以 上的 額定負載	電源未 處於過溫 保護模式	輸入電壓 正常， 未觸發 UVP功能	輸出電壓 正常， 未觸發 OVP功能	電源工作 正常， 無故障	資料 記憶體 正常工作， 無故障	系統正常 工作， 未關閉

59	60
29	0D
右括弧	結束符
)	回傳結束

4 C指令傳輸

以NTS-750-248UN機型為例,進行遙控關機指令。

請求指令：43 31 30 30 30 30 30 30 30 30 30 30 30 30 30 30 0D

回傳指令：43

請求指令解釋：

數位	0	1	2	3-15	16
請求	43	31	30	30	0D
功能	C指令確認	Shut down	Turn on INVERTER	無特殊功能， 預留其它位置	結束符
解釋	C指令寫入	關機指令 開啟	開機指令 關閉		指令結束

回傳指令解釋：

數位	0
請求	43
功能	C指令回傳
解釋	C指令生效

5 V指令傳輸

以NTS-750-248UN機型為例，變更輸出頻率為60Hz。

(1) 首先以pu指令解鎖

輸入指令：70 55 0D

無回傳

(2) 輸入指令：56 32 33 30 20 30 36 30 01 A1 0D

回傳指令：23 32 33 30 20 30 36 30 01 6E 0D

輸入指令解釋：

數位	0	1-3	4	5-7	8-9	10
請求	56	32 33 30	20	30 36 30	01 A1	0D
功能	V指令確認	輸出電壓 設定	間隔符號	頻率設定	校驗	結束符
解釋	V指令寫入	230V	空格	60Hz	校驗位	指令結束

輸出指令解釋：

數位	0	1-3	4	5-7	8-9	10
請求	23	32 33 30	20	30 36 30	01 6E	0D
功能	#	輸出電壓 讀取	間隔 符號	頻率讀取	校驗	結束符
解釋	#	230V	空格	60Hz	校驗位	指令結束

6 I指令傳輸

以NTS-750-248UN機型為例，讀取逆變器資訊。

請求指令：49 0D

回傳指令：23 03 00 05 30 30 2E 30 20 30 30 2E 30 20 34 34 2E 30 20 34 30
2E 30 20 30 30 2E 30 20 4D 45 41 4E 57 45 4C 4C 20 20 20 4C 4F 43 2D 30
31 32 33 34 35 36 37 38 39 20 20 20 20 20 20 52 45 56 3A 30 31 2E 34 20
20 4E 54 53 2D 30 37 35 30 2D 32 34 38 20 20 31 20 30 30 2F 30 30 2F 30
30 30 30 12 6C 0D

請求指令解釋:

數位	0	1
輸入	49	0D
功能	W 指令確認	結束符
解釋	W 指令寫入	指令結束

回傳指令解釋:

數位	0	1	2	3	4-7	8	9-12	13
回傳	23	03	00	05	30 30 2E 30	20	30 30 2E 30	20
功能	#	電壓/頻率 檔位元	Saving Mode	Mode code	均充電壓 讀取	間隔 符號	浮充電壓 讀取	間隔 符號
解釋	#	240V/ 50Hz	省電模 式關閉	機型為 248	0V	空格	0V	空格

14-17	18	19-22	23	24-27	28	29-38
34 34 2E 30	20	34 30 2E 30	20	30 30 2E 30	20	4D 45 41 4E 57 45 4C 4C 20 20
警告電壓 讀取	間隔 符號	停機電 壓讀取	間隔 符號	轉換電 壓讀取	間隔 符號	製造廠商
44.0V	空格	40.0V	空格	0V	空格	MEANWELL

39	40-58	59	60-68
20	4C 4F 43 2D 30 31 32 33 34 35 36 37 38 39 20 20 20 20 20	20	52 45 56 3A 30 31 2E 34 20
間隔符號	產品序號	間隔符號	韌體版本
空格	LOC-123456789	空格	REV:01.4

69	70-82	83	84	85	86-95
20	4E 54 53 2D 30 37 35 30 2D 32 34 38 20	20	31	20	30 30 2F 30 30 30 2F 30 30 30 30
間隔 符號	機型名稱	間隔 符號	電池 輸出 優先	間隔 符號	日期
空格	NTS-0750-248	空格	開啟	空格	0月0日0000年

96-97	98
12 6C	0D
校驗	結束符
校驗位	回傳結束

7 W指令傳輸

以NTS-750-248UN機型為例，W指令寫入修改告警電壓改為42.0V。

請求指令：57 03 00 05 36 30 2E 30 20 36 30 2E 30 20 34 32 2E 30 20 34 30 2E 30
20 36 30 2E 30 20 4D 45 41 4E 57 45 4C 4C 20 20 20 4C 4F 43 2D 30 31 32 33 34
35 36 37 38 39 20 20 20 20 20 20 52 45 56 3A 30 31 2E 34 20 20 4E 54 53 2D 30
37 35 30 2D 32 34 38 20 20 31 20 30 30 2F 30 30 2F 30 30 30 12 B0 0D
回傳指令：23 03 00 05 30 30 2E 30 20 30 30 2E 30 20 34 32 2E 30 20 34 30 2E 30
20 30 30 2E 30 20 4D 45 41 4E 57 45 4C 4C 20 20 20 4C 4F 43 2D 30 31 32 33 34
35 36 37 38 39 20 20 20 20 20 20 52 45 56 3A 30 31 2E 34 20 20 4E 54 53 2D 30
37 35 30 2D 32 34 38 20 20 31 20 30 30 2F 30 30 2F 30 30 30 12 6A 0D

請求指令解釋:

數位	0	1	2	3	4-7	8	9-12	13
請求	57	03	00	05	36 30 2E 30	20	36 30 2E 30	20
功能	W指令 確認	電壓/頻率 檔位元	Saving Mode	Mode code	均充電壓 設定	間隔 符號	浮充電壓 設定	間隔 符號
解釋	W指令 確認	240V/ 50Hz	省電模 式關閉	機型為 248	60V	空格	60V	空格

14-17	18	19-22	23	24-27	28	29-38
34 32 2E 30	20	34 32 2E 30	20	36 30 2E 30	20	4D 45 41 4E 57 45 4C 4C 20 20
警告電壓 設定	間隔 符號	停機電 壓設定	間隔 符號	轉換電 壓設定	間隔 符號	製造廠商
42.0V	空格	40.0V	空格	60V	空格	MEANWELL

39	40-58	59	60-68
20	4C 4F 43 2D 30 31 32 33 34 35 36 37 38 39 20 20 20 20 20	20	52 45 56 3A 30 31 2E 34 20
間隔符號	產品序號	間隔符號	韌體版本
空格	LOC-123456789	空格	REV:01.4

69	70-82	83	84	85	86-95
20	4E 54 53 2D 30 37 35 30 2D 32 34 38 20	20	31	20	30 30 2F 30 30 30 2F 30 30 30 30
間隔符號	機型名稱	間隔符號	電池輸出優先	間隔符號	日期
空格	NTS-0750-248	空格	開啟	空格	0月0日0000年

96-97	98
12 6C	0D
校驗	結束符
校驗位	回傳結束

W回傳指令可參考I指令回傳指令解釋。

8 U指令傳輸

以NTU-1700-148UN機型為例，U指令讀取逆變器電池UVP和OVP電壓切換點（使用U指令之前需要通過W指令把Battery First Flag置1，或者操作DIPSW啟用電池優先功能）

請求指令：55 0D

回傳指令：23 34 34 2E 30 20 35 37 2E 36 20 30 30 2E 30 20 30 30 2E 30 20 30 30 2E 30 05 83 0D

請求指令解釋：

數位	0	1
請求	55	0D
功能	U指令確認	結束符
解釋	U指令確認	指令結束

回傳指令解釋：

數位	0	1~4	5	6~9	10	11~14	15	16~19
請求	23	34 34 2E 30	20	35 37 2E 36	20	30 30 2E 30	20	30 30 2E 30
功能	#	電池UVP 切換點電壓 設定	間隔符號	電池OVP 切換點電壓 設定	間隔符號	無特殊功 能，預留其 它位置	間隔符號	無特殊功 能，預留其 它位置
解釋	#	44.0V	空格	57.6V	空格	00.0V不支持 修改	空格	00.0V不支持 修改
數位	20	21~24	25	26~29	30 31	32		
請求	20	30 30 2E 30	20	30 30 2E 30	05 51	0D		
功能	間隔符號	無特殊功 能，預留其 它位置	間隔符號	無特殊功 能，預留其 它位置	校驗	結束符		
解釋	空格	00.0V不支持 修改	空格	00.0V不支持 修改	校驗位	回傳結束		

以NTU-1700-148UN機型為例，U指令寫入逆變器UVP電壓切換點44.0V和OVP電壓切換點57.6V

請求指令：55 34 34 2E 30 20 35 37 2E 36 20 30 30 2E 30 20 30 30 2E 30 20 30 30 2E 30 05 83 0D

回傳指令：23 34 34 2E 30 20 35 37 2E 36 20 30 30 2E 30 20 30 30 2E 30 20 30 30 2E 30 05 1E 0D

請求指令解釋：

數位	0	1~4	5	6~9	10	11~14	15	16~19
請求	55	34 34 2E 30	20	35 37 2E 36	20	30 30 2E 30	20	30 30 2E 30
功能	U指令 確認	電池UVP 切換點電壓 設定	間隔符號	電池OVP 切換點電壓 設定	間隔符號	無特殊功 能，預留其 它位置	間隔符號	無特殊功 能，預留其 它位置
解釋	U指令 確認	44.0V	空格	57.6V	空格	00.0V不支持 修改	空格	00.0V不支持 修改
數位	20	21~24	25	26~29	30 31	32		
請求	20	30 30 2E 30	20	30 30 2E 30	05 83	0D		
功能	間隔符號	無特殊功 能，預留其 它位置	間隔符號	無特殊功 能，預留其 它位置	校驗	結束符		
解釋	空格	00.0V不支持 修改	空格	00.0V不支持 修改	校驗位	指令結束		

回傳指令解釋：

數位	0	1~4	5	6~9	10	11~14	15	16~19
請求	23	34 34 2E 30	20	35 37 2E 36	20	30 30 2E 30	20	30 30 2E 30
功能	#	電池UVP 切換點電壓 設定	間隔符號	電池OVP 切換點電壓 設定	間隔符號	無特殊功 能·預留其 它位置	間隔符號	無特殊功 能·預留其 它位置
解釋	#	44.0V	空格	57.6V	空格	00.0V不支持 修改	空格	00.0V不支持 修改
數位	20	21~24	25	26~29	30 31	32		
請求	20	30 30 2E 30	20	30 30 2E 30	05 1E	0D		
功能	間隔符號	無特殊功 能·預留其 它位置	間隔符號	無特殊功 能·預留其 它位置	校驗	結束符		
解釋	空格	00.0V不支持 修改	空格	00.0V不支持 修改	校驗位	指令結束		

5.5 UPS模式(僅NTU系列)

5.5.1 UPS模式說明

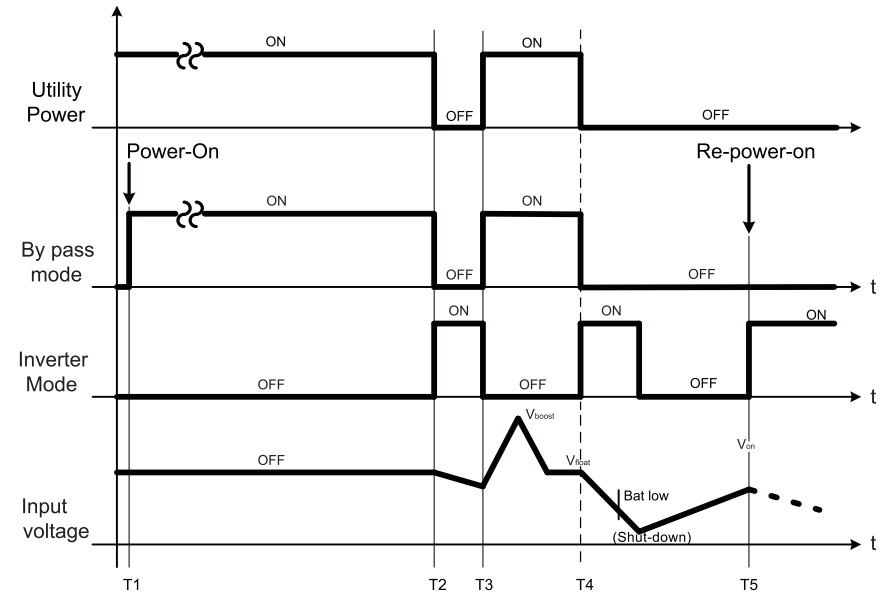

T1: 當使用者將NTU-1200/1700/2200/3200開機後，如果偵測到市電電壓正常時，NTU會進入旁路模式(Bypass mode)直接供應市電至負載，此時電池已處於充飽狀態。

T2: 若市電電壓瞬間斷電無法供應AC輸出或是當市電電壓瞬間超出NTU設定輸出的 $\pm 16\%$ 範圍時，NTU會立即轉換為逆變模式(inverter mode)，讓客戶設備不會因市電不穩而有斷電之虞。以NTU-1200-124(預設值110Vac)為例：當市電電壓大於127.6Vac以上或是小於92.4Vac以下，NTU-1200-124會進入逆變模式供電，此時電池開始提供能量，給逆變器達成備援功能。

T3: 若市電已恢復正常或市電電壓在NTU設定輸出的 $\pm 13\%$ 範圍以內，NTU將再度轉換至Bypass模式，由市電供電至負載，此時電池可以透過外部充電器完成充電程序。

T4: 當電池組電壓消耗到逆變器輸入電壓下限，且處於停電狀態。此時外接的電池充電器無法提供能量，因此逆變器會持續動作直到電池電壓低於操作電壓下限。

T5: 當外部電池電壓，因市電回復且外接充電器，將電池電壓充電，至逆變器工作電壓時，逆變器自動重啟並運作。

T6: NTU-1700系列及以上功率機型在Bypass模式工作，由市電供電至負載時，逆變器須接入電池組啟動風扇散熱。

5.5.2 UPS模式配置參考圖

NTU-1200/1700/2200/3200使用時必須與充電器搭配，以維持UPS模式的工作品質。NTU於bypass模式工作時，充電器可維護電池電壓，提供足夠的電量供市電異常時的逆變器模式使用。而當市電異常回復時，充電器也可補足在變流模式下運轉所損耗的電力。連接充電器時請依輸出電流挑選合適線徑之線材做為連接電池及逆變器用，請參考表3-1線材使用建議表。

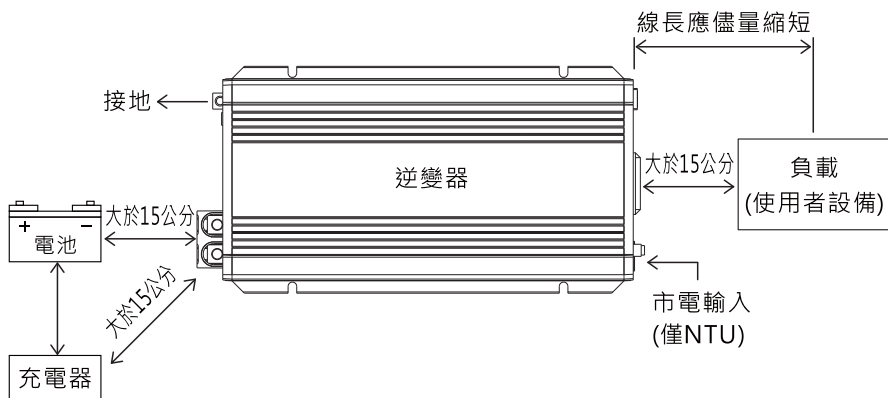

(建議可搭配明緯NPB/NPP系列)

6. 保護功能及異常排除

6.1 保護功能

AC輸出端保護：

- 輸出過載保護：

當負載超載時，逆變器可短時間充電。若負載量沒有下降到正常額定範圍，將會發生OLP保護關機，需排除超載狀況後重新開機始可恢復正常運行。

- AC輸出短路保護：

當逆變器之輸出端發生短路情況或負載驟升時，逆變器會關機，排除短路後需重新開機，始可恢復正常發生。

DC輸入端保護：

- DC極性反接保護：

當DC輸入端子接反時，逆變器內部保險絲會被燒斷。逆變器需送回原廠或明緯授權經銷商維修。

- DC電壓過低電壓保護：

當DC低於規格值時，逆變器將會自動關閉，避免電池過放電以保護電池使用壽命。

- DC電壓過高電壓保護：

當DC過高時，逆變器將會自動關閉輸出，若排除DC輸入電壓過高後重新關機，逆變器仍無法正常運作，可能是逆變器已損壞，請送回原廠或明緯授權經銷商維修。

逆變器保護：

過溫度保護(OTP)：

當逆變器內部溫度過高時，逆變器將會自動關閉輸出，排除後需重新將逆變器關機。

6.2 異常排除

若發生異常情況時，本機面板顯示將出現故障訊息燈號，以供故障排除參考。異常情況可分為四大類，AC輸出保護、DC輸入端保護、溫升/保護或是其他逆變器異常。建議可以依據下表檢查及排除，若還是無法恢復正常，請就近洽詢明緯全球授權經銷商或原廠諮詢。

故障燈號	可能引起原因	建議解除方式
Status ● DC Input ○ Load ●	過載保護	檢查負載是否超過額定值或負載瞬間需要過大啟動電流，如電感或是電容性設備，解除異常後，單體自動回復。
	短路保護	檢查負載是否超過額定值或短路解除異常後，單體自動回復。
Status ● DC Input ● Load ○	電池老化或故障	更新電池
	電池搭配錯誤	檢查電池電壓是否符合逆變器之規格
Status ● DC Input ● Load ●	過溫保護	檢查散熱通風口是否通暢。如是室溫過高，請降載使用或降低環境溫度，解除異常後，需AC重啟方可使用。
Status ● DC Input ○ Load ○	其他異常	請退回原廠維修

註: ● 恆亮
 ● 閃爍
 ○ 熄滅

7.保固

本產品符合規格條件下，可提供3年之無償免費維修服務。請勿自行更換零件或對本產品進行任何形式的修改或維修，以免影響您享有正常保固服務之權利。

※ 明緯保有修訂使用手冊之權利，若有修訂，請以明緯官網資訊為準。<https://www.meanwell.com>



MEAN WELL WEB

Inverter Manual

8. 環境宣告資訊

https://www.meanwell.com//Upload/PDF/RoHS_PFOS.pdf

https://www.meanwell.com//Upload/PDF/REACH_SVHC.pdf

https://www.meanwell.com//Upload/PDF/Declaration_RoHS-C.pdf

明緯企業股份有限公司

MEAN WELL ENTERPRISES CO., LTD.

248 新北市五股區五權三路28號

No.28, Wuquan 3rd Rd., Wugu Dist., New Taipei City 248, Taiwan

Tel:886-2-2299-6100 Fax:886-2-2299-6200

<http://www.meanwell.com> E-mail:info@meanwell.com